

CONSTRUCTION

Available Material	Polyvinylidene Fluoride (PVDF) - <i>BLACK & NATURAL</i>
Unit Weight (with box)	0.22 lbs
Inlet & Outlet Connections	0.75" male NPT
Suction Port Cap Connection - Default (Inner Diameter)	0.25" tubing barb
Suction Port Cap Connection - Alternate	0.25" male NPT
Maximum Operating Temperature	212° F
Maximum Operating Pressure (at 68° F)	120 PSI

ACCESSORIES

PART NUMBER	DESCRIPTION
K-184	Suction line kit
K-F-30L	K-184 suction line kit with F-30 L liquid flowmeter
K-184-B	Bypass kit (includes suction line kit K-184)
MV-25	0.25" PP metering valve with valve position indicator ring
MV-25A	0.25" PP metering valve
S-25HB	Strainer with 0.25" barbed connection

REPLACEMENT PARTS

INJECTOR MODEL	SUCTION PORT CAP	CHECK VALVE REPAIR KIT
0684 PVDF <i>BLACK</i>	CAP .375 PVDF	CR-2
0684 N-PVDF <i>NATURAL</i>	CAP.375 N-PVDF	CR-2



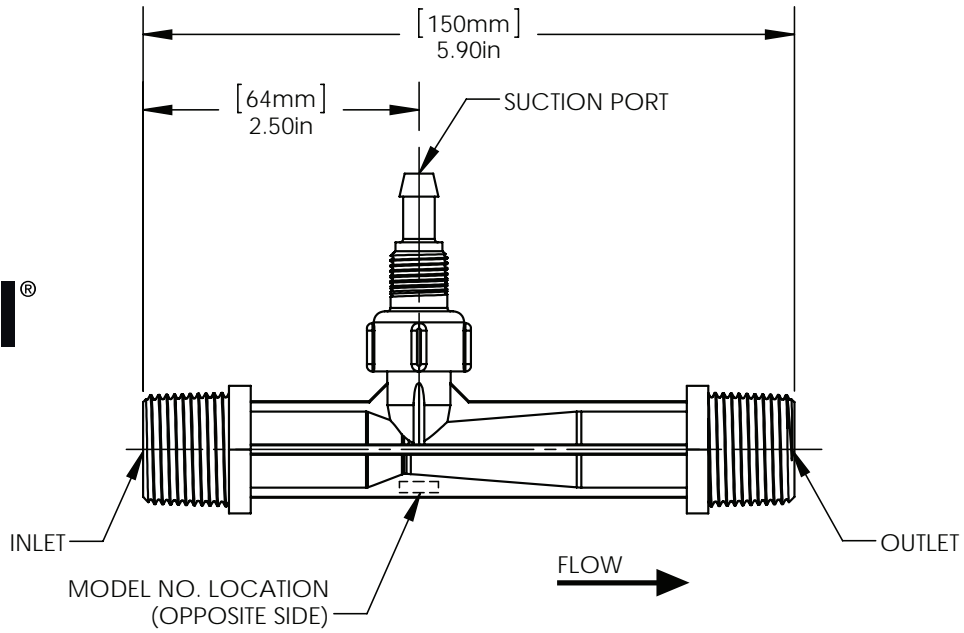

CONSTRUCTION

Available Material	Polyvinylidene Fluoride (PVDF) - <i>BLUE</i>
Unit Weight (with box)	0.09 kg
Inlet & Outlet Connections	20 mm male BSPT
Suction Port Cap Connection - Default (Inner Diameter)	0.25" tubing barb
Suction Port Cap Connection - Alternate	0.25" male NPT
Maximum Operating Temperature	100° C
Maximum Operating Pressure (at 20° C)	8.44 bar

ACCESSORIES

PART NUMBER	DESCRIPTION
MV-25	0.25" PP metering valve with valve position indicator ring
MV-25A	0.25" PP metering valve
S-25HB	Strainer with 0.25" barbed connection

REPLACEMENT PARTS

INJECTOR MODEL	SUCTION PORT CAP	CHECK VALVE REPAIR KIT
ISO 0684 PVDF <i>BLUE</i>	N/A	CR-2