

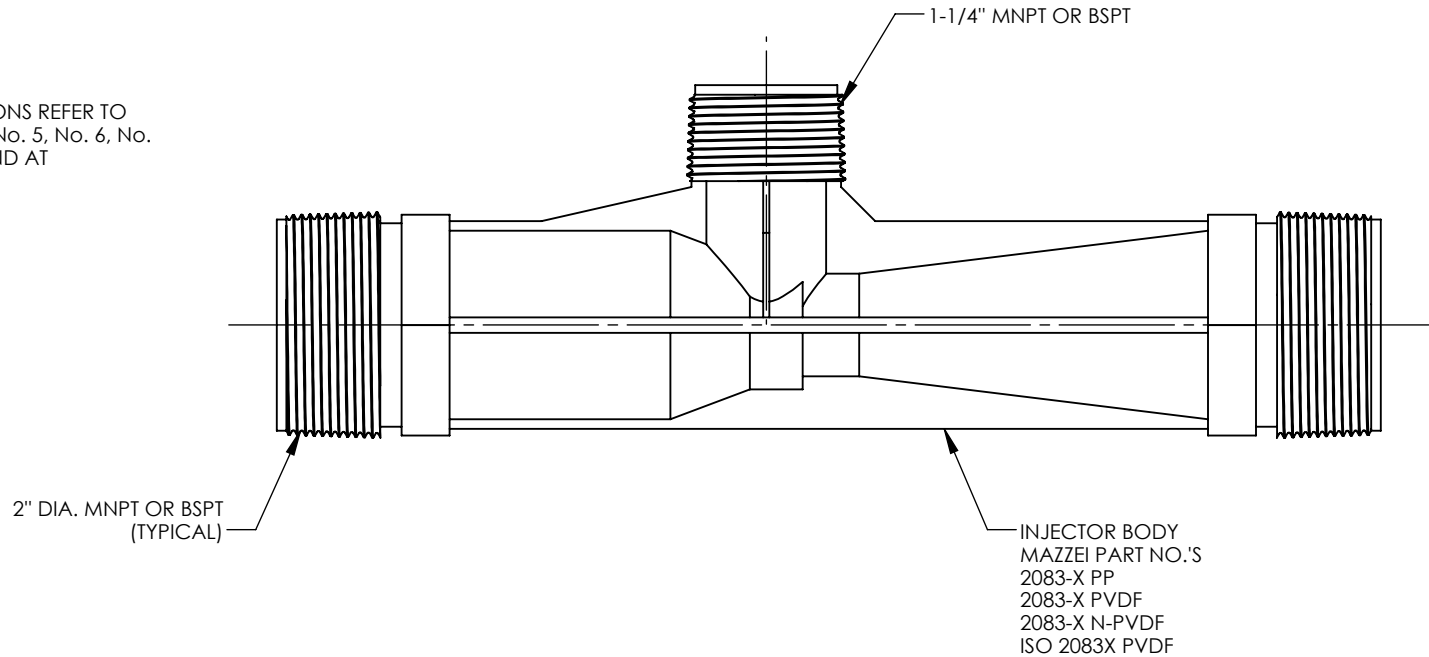

NOTES:

1. MADE IN THE U.S.A.
2. U.S. PATENT No. 5,863,128
3. U.S. No. 3,852,076 AND INTERNATIONAL REGISTERED TRADEMARKS
4. MATERIAL: GLASS FILLED POLYPROPYLENE (PP) OR POLYVINYLIDENE FLUORIDE (PVDF)
5. INLET/OUTLET CONNECTION:  
2" DIA. MNPT OR BSPT
6. SUCTION PORT CONNECTION:  
1-1/4" MNPT OR BSPT
7. FOR INSTALLATION RECOMMENDATIONS REFER TO MAZZEI TECHNICAL BULLETINS No. 4, No. 5, No. 6, No. 10 AND No. 11, WHICH CAN BE FOUND AT WWW.MAZZEI.NET.
8. MAZZEI INJECTOR CO., LLC.  
500 ROOSTER DR.  
BAKERSFIELD, CA 93307  
TEL: 661.363.6500  
WEB: WWW.MAZZEI.NET



UNLESS OTHERWISE SPECIFIED DIMENSIONS ARE IN INCHES			TITLE: 2" INJECTOR; MODEL 2083-X		
DRAWN: J. PEREZ	DATE: 9/24/2014		DRAWING NO.: 2083-X		
APPROVED: T. JOHNS	SIZE: <b>A</b>	WEIGHT: N/A	SCALE: 1:2	REV.: B	SHEET: 1 OF 2

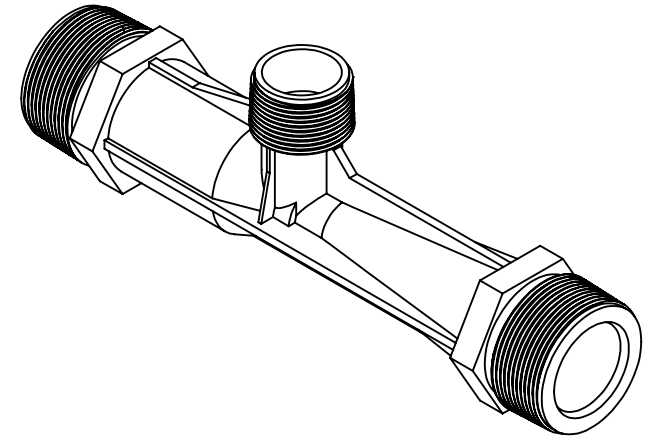

(ISOMETRIC VIEW)  
(FOR REFERENCE ONLY)

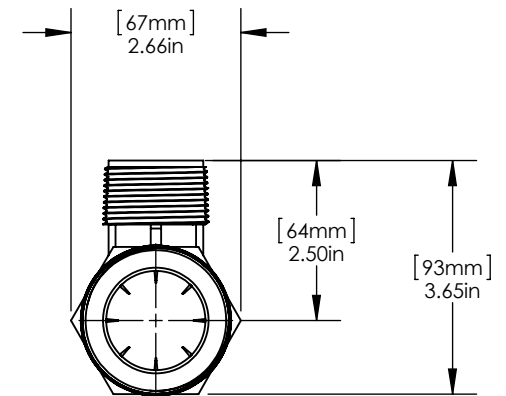
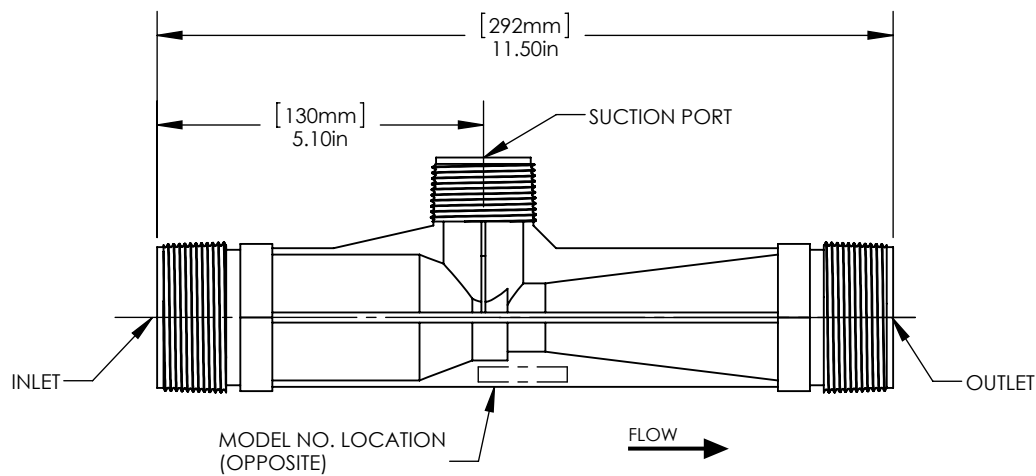

UNLESS OTHERWISE SPECIFIED DIMENSIONS ARE IN INCHES		 <b>Mazzei</b>	TITLE: 2" INJECTOR; MODEL 2083-X		
DRAWN: J. PEREZ	DATE: 9/24/2014		DRAWING NO.: 2083-X		
APPROVED: T. JOHNS	SIZE: <b>A</b>	WEIGHT: N/A	SCALE: 1:3	REV.: B	SHEET: 2 OF 2