

NOTES:

1. MADE IN THE U.S.A.
2. U.S. PATENT No. 5,863,128
3. U.S. No. 3,852,076 AND INTERNATIONAL REGISTERED TRADEMARKS
4. MATERIAL: GLASS FILLED POLYPROPYLENE (PP) OR POLYVINYLIDENE FLUORIDE (PVDF) OR NATURAL POLYVINYLIDENE FLUORIDE (N-PVDF).
5. INLET/OUTLET CONNECTION:
1" MNPT OR BSPT
6. SUCTION PORT CONNECTION:

DEFAULT - 1/2" I.D. TUBING BARB WITH INTEGRATED CHECK VALVE

ALTERNATE - 1/2" MNPT - SEE ALTERNATE CAP MODIFICATION DETAIL
7. FOR INSTALLATION RECOMMENDATIONS REFER TO MAZZEI TECHNICAL BULLETINS No. 4, No. 5, No. 6, No. 10 AND No. 11, WHICH CAN BE FOUND AT WWW.MAZZEI.NET.
8. MAZZEI INJECTOR CO., LLC.
500 ROOSTER DR.
BAKERSFIELD, CA 93307
TEL: 661.363.6500
WEB: WWW.MAZZEI.NET

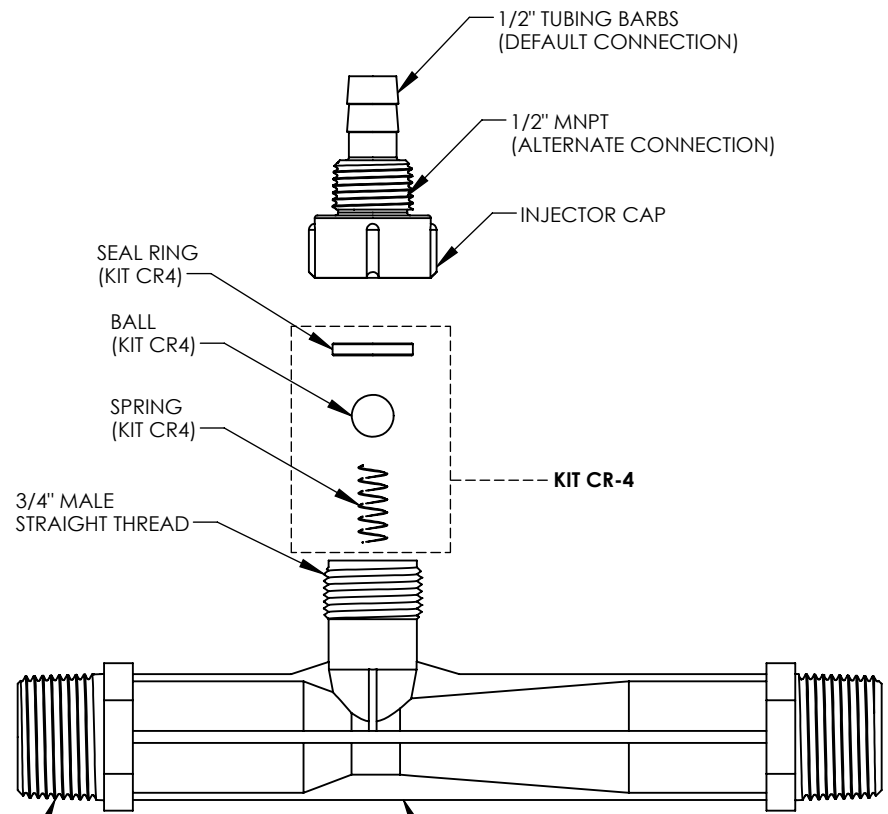

1" MNPT OR BSPT (TYPICAL)

INJECTOR BODY
MAZZEI PART NO.'S
0978 3 PP
0978 3 PVDF
0978 3 N-PVDF
ISO 0978 3 GRPP
ISO 0978 3 PVDF

KIT CR-4	
TITLE	MATERIAL
BALL	TEFLON @ (PTFE)
SEAL RING	KEL-F @ (PCTFE)
SPRING	HASTELLOY C-22

REMOVE HOSE BARBS FROM CAP AND DISCARD

[3mm]
0.13in
MAXIMUM
STICKOUT

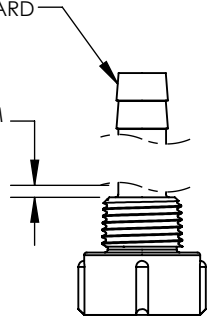

"CAP MODIFICATION DETAIL"
(ALTERNATE)

UNLESS OTHERWISE SPECIFIED DIMENSIONS ARE IN INCHES			TITLE: 1" INJECTOR; MODEL 0978 3		
DRAWN: T. JOHNS	DATE: 7/19/2013		DRAWING NO.: 0978 3		
APPROVED: P. BANKOWSKI	SIZE: A	WEIGHT: N/A	SCALE: 1:2	REV.: B	SHEET: 1 OF 2

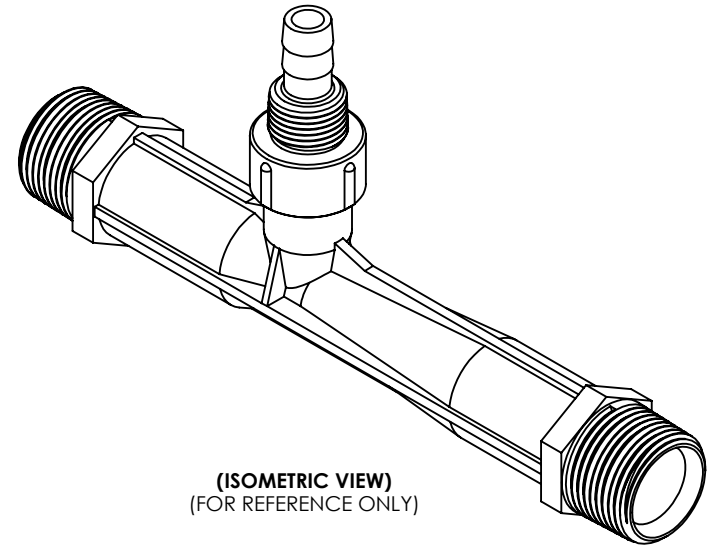

(ISOMETRIC VIEW)
(FOR REFERENCE ONLY)

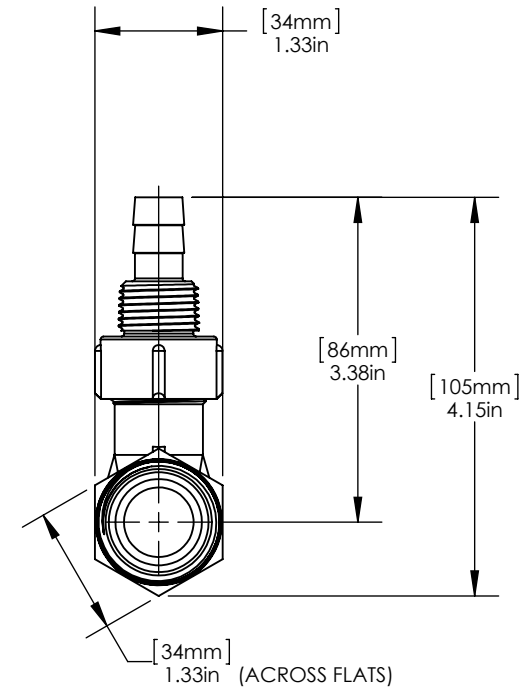
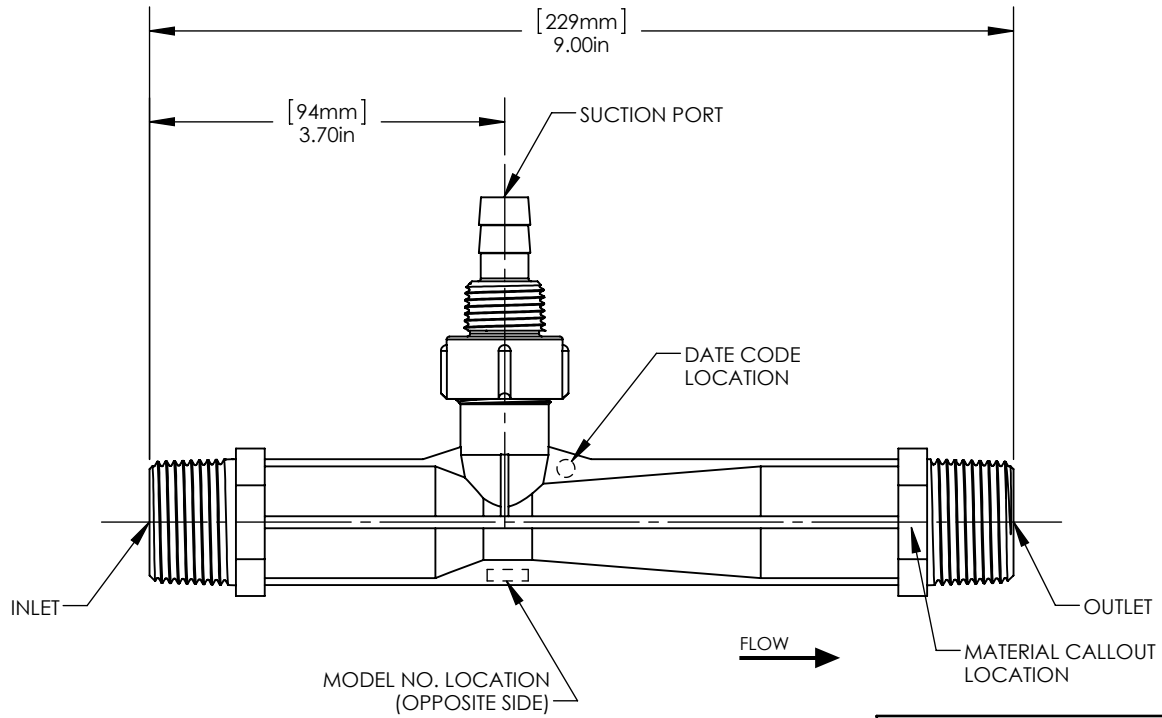

UNLESS OTHERWISE SPECIFIED DIMENSIONS ARE IN INCHES			TITLE: 1" INJECTOR; MODEL 0978 3		
DRAWN: T. JOHNS	DATE: 7/19/2013		DRAWING NO.: 0978 3		
APPROVED: P. BANKOWSKI	SIZE: A	WEIGHT: N/A	SCALE: 1:2	REV.: B	SHEET: 2 OF 2