

NOTES:

1. MADE IN THE U.S.A.
2. U.S. PATENT No. 5,863,128
3. U.S. No. 3,852,076 AND INTERNATIONAL REGISTERED TRADEMARKS
4. MATERIAL: GLASS FILLED POLYPROPYLENE (PP) OR POLYVINYLIDENE FLUORIDE (PVDF) OR NATURAL POLYVINYLIDENE FLUORIDE (N-PVDF) .
5. INLET/OUTLET CONNECTION:
1" MNPT OR BSPT
6. SUCTION PORT CONNECTION:

DEFAULT - 1/2" I.D. TUBING BARB WITH INTEGRATED CHECK VALVE

ALTERNATE - 1/2" MNPT - SEE ALTERNATE CAP MODIFICATION DETAIL
7. FOR INSTALLATION RECOMMENDATIONS REFER TO MAZZEI TECHNICAL BULLETINS No. 4, No. 5, No. 6, No. 10 AND No. 11, WHICH CAN BE FOUND AT WWW.MAZZEI.NET.
8. MAZZEI INJECTOR CO., LLC.
500 ROOSTER DR.
BAKERSFIELD, CA 93307
TEL: 661.363.6500
WEB: WWW.MAZZEI.NET

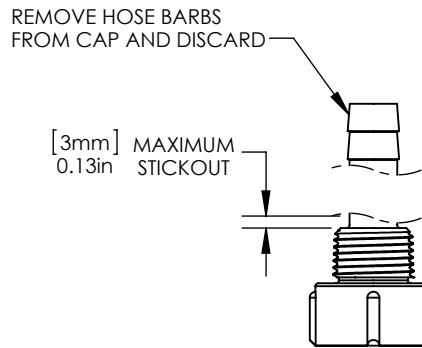
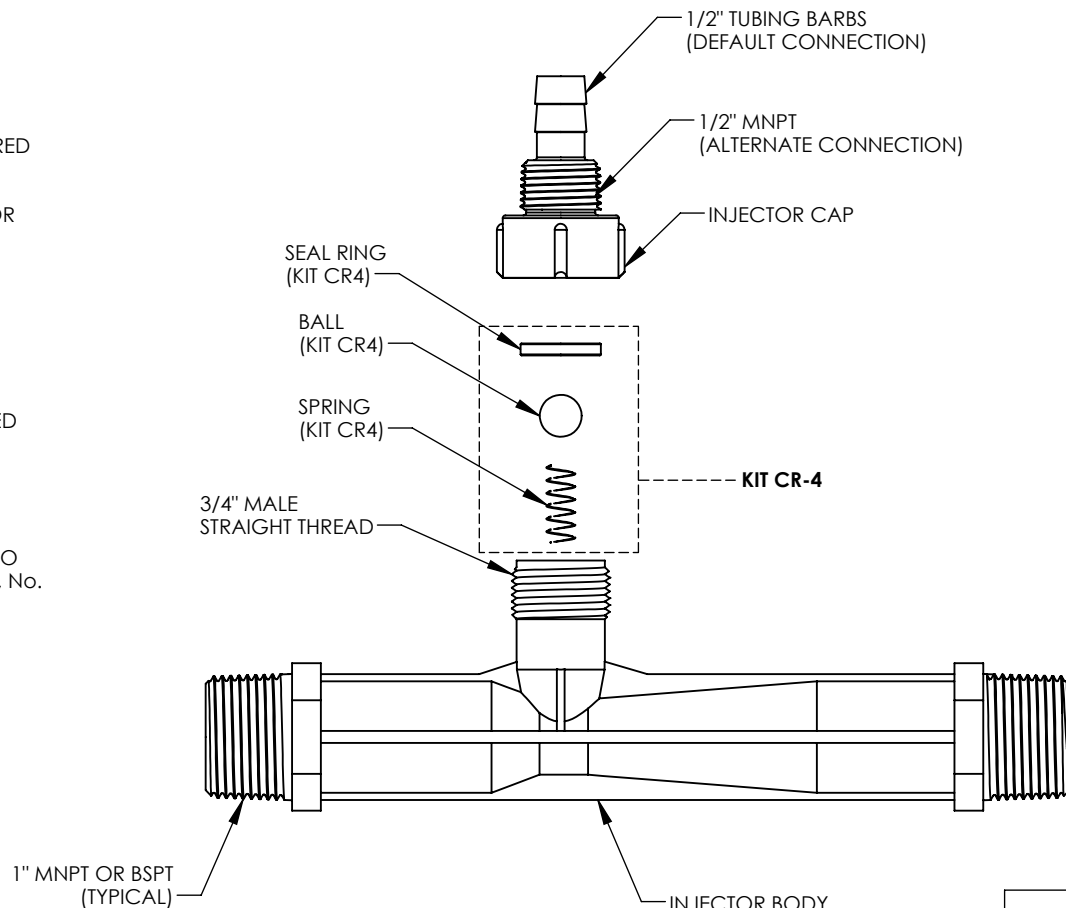

"CAP MODIFICATION DETAIL"
(ALTERNATE)

INJECTOR BODY
MAZZEI PART NO.'S
0885X 3 PP
0885X 3 PVDF
0885X 3 N-PVDF
ISO 0885X 3 GRPP
ISO 0885X 3 PVDF

KIT CR-4	
TITLE	MATERIAL
BALL	TEFLON @ (PTFE)
SEAL RING	KEL-F @ (PCTFE)
SPRING	HASTELLOY C-22

UNLESS OTHERWISE SPECIFIED DIMENSIONS ARE IN INCHES			TITLE: 1" INJECTOR; MODEL 0885X 3			
DRAWN:	T. JOHNS		DRAWING NO.:			
DATE:	7/19/2013	0885X 3				
APPROVED:	P. BANKOWSKI	SIZE: A	WEIGHT: N/A	SCALE: 1:2	REV.: B	SHEET: 1 OF 2

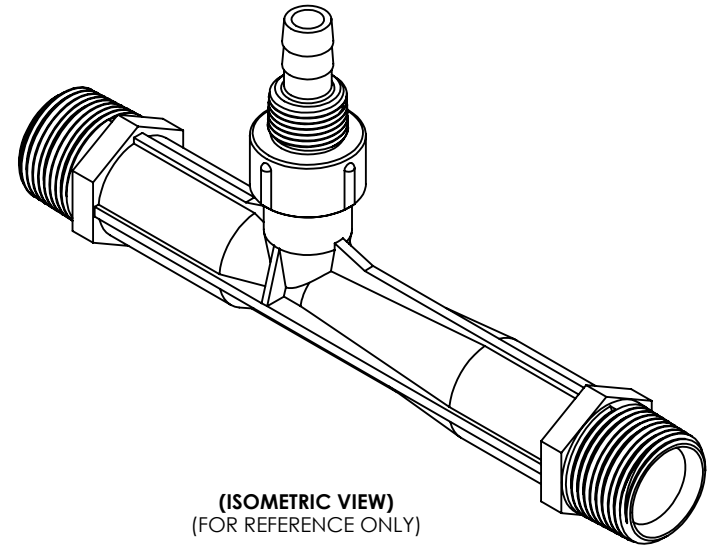

(ISOMETRIC VIEW)
(FOR REFERENCE ONLY)

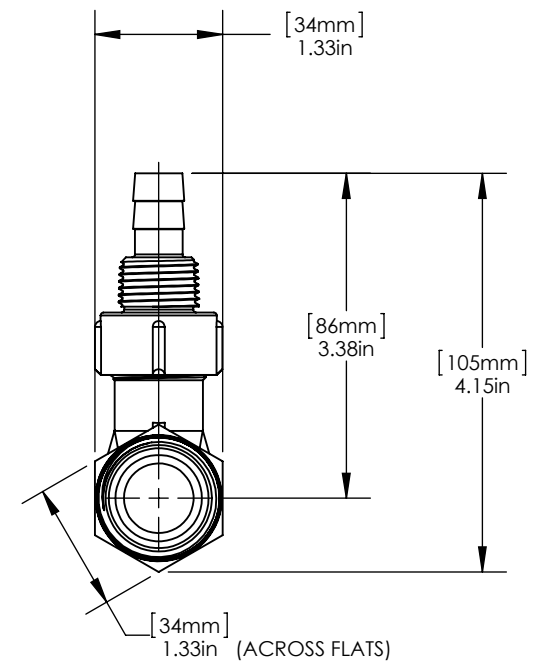
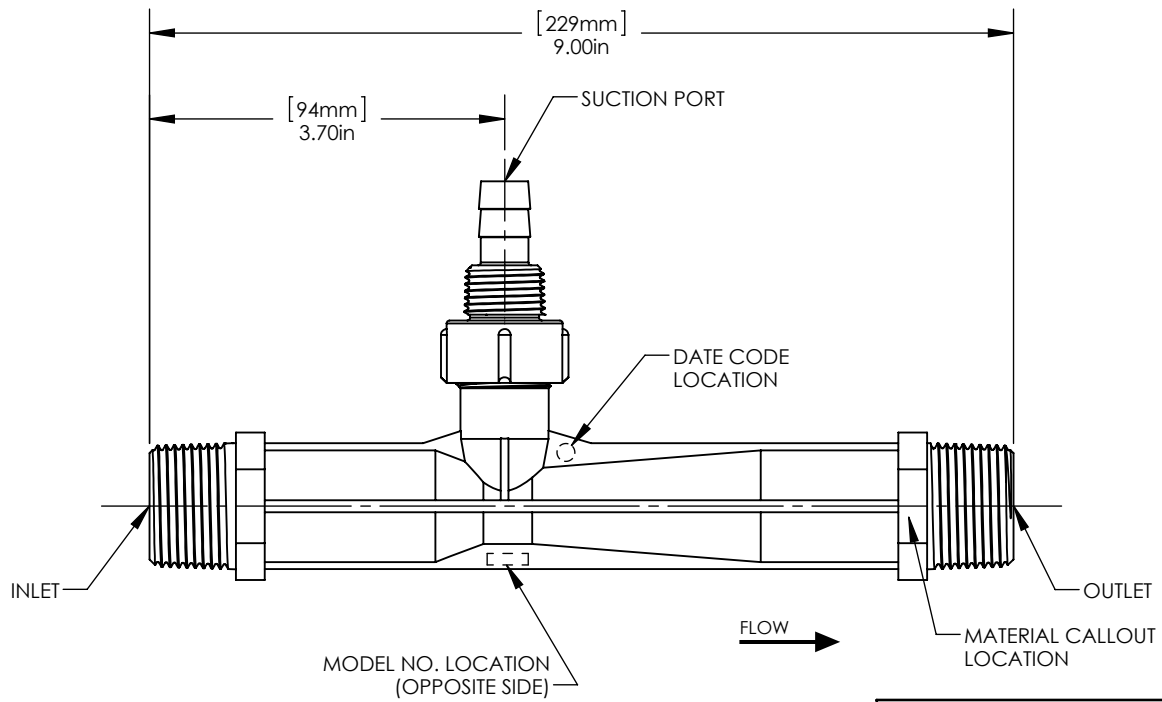

UNLESS OTHERWISE SPECIFIED DIMENSIONS ARE IN INCHES			TITLE: 1" INJECTOR; MODEL 0885X 3		
DRAWN: T. JOHNS	DATE: 7/19/2013		DRAWING NO.: 0885X 3		
APPROVED: P. BANKOWSKI	SIZE: A	WEIGHT: N/A	SCALE: 1:2	REV.: B	SHEET: 2 OF 2