

NOTES:

1. MADE IN THE U.S.A.
2. U.S. PATENT No. 5,863,128
3. U.S. No. 3,852,076 AND INTERNATIONAL REGISTERED TRADEMARKS
4. MATERIAL: GLASS FILLED POLYPROPYLENE (PP) OR POLYVINYLIDENE FLUORIDE (PVDF) OR NATURAL POLYVINYLIDENE FLUORIDE (N-PVDF)
5. INLET/OUTLET CONNECTION:  
1" MNPT OR BSPT
6. SUCTION PORT CONNECTION:  
  
DEFAULT - 1/2" I.D. TUBING BARB WITH INTEGRATED CHECK VALVE  
  
ALTERNATE - 1/2" MNPT - SEE ALTERNATE CAP MODIFICATION DETAIL
7. FOR INSTALLATION RECOMMENDATIONS REFER TO MAZZEI TECHNICAL BULLETINS No. 4, No. 5, No. 6, No. 10 AND No. 11, WHICH CAN BE FOUND AT WWW.MAZZEI.NET.
8. MAZZEI INJECTOR CO., LLC.  
500 ROOSTER DR.  
BAKERSFIELD, CA 93307  
TEL: 661.363.6500  
WEB: WWW.MAZZEI.NET

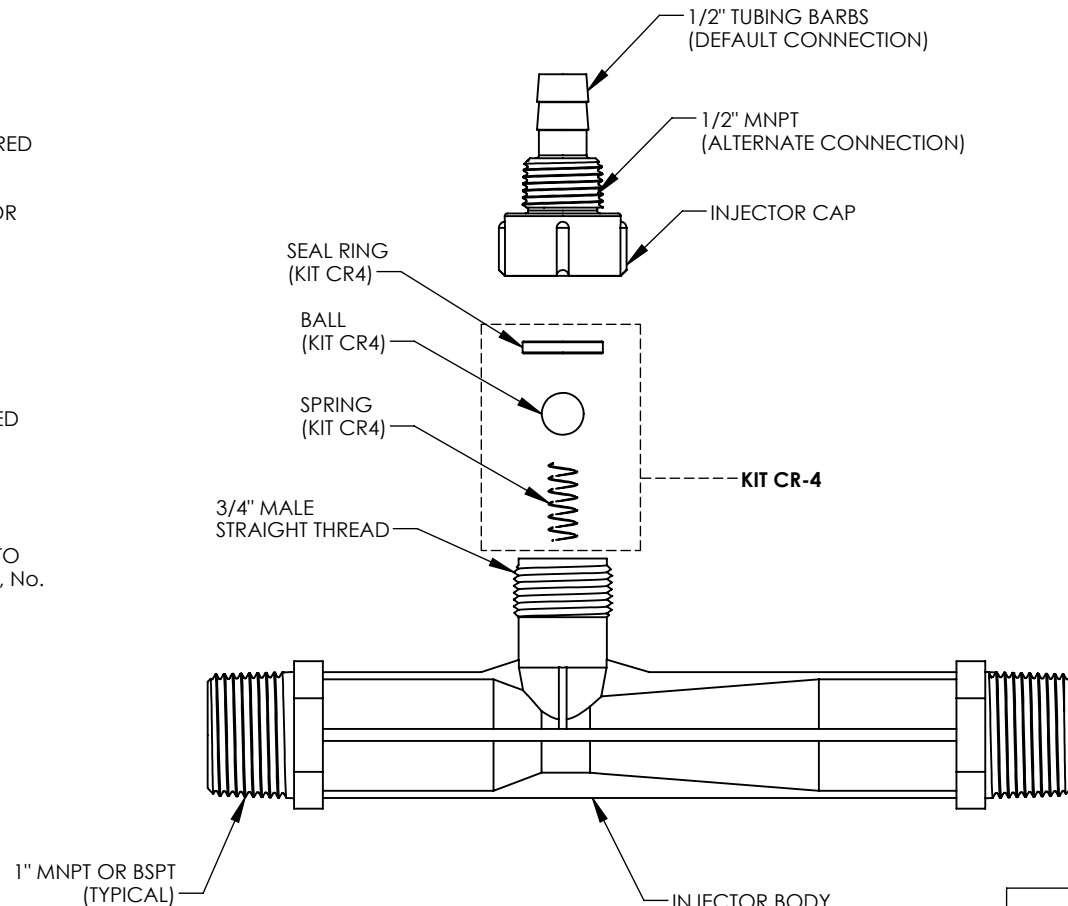

INJECTOR BODY  
MAZZEI PART NO.'S  
0878 3 PP  
0878 3 PVDF  
0878 3 N-PVDF  
ISO 0878 3 GRPP  
ISO 0878 3 PVDF

KIT CR-4	
TITLE	MATERIAL
BALL	TEFLON @ (PTFE)
SEAL RING	KEL-F @ (PCTFE)
SPRING	HASTELLOY C-22

REMOVE HOSE BARBS FROM CAP AND DISCARD

[3mm] MAXIMUM  
0.13in STICKOUT

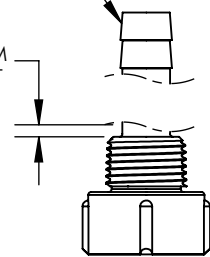

"CAP MODIFICATION DETAIL"  
(ALTERNATE)

UNLESS OTHERWISE SPECIFIED DIMENSIONS ARE IN INCHES			TITLE: 1" INJECTOR; MODEL 0878 3		
DRAWN: T. JOHNS	DATE: 7/19/2013		DRAWING NO.: 0878 3		
APPROVED: P. BANKOWSKI	SIZE: <b>A</b>	WEIGHT: N/A	SCALE: 1:2	REV.: B	SHEET: 1 OF 2

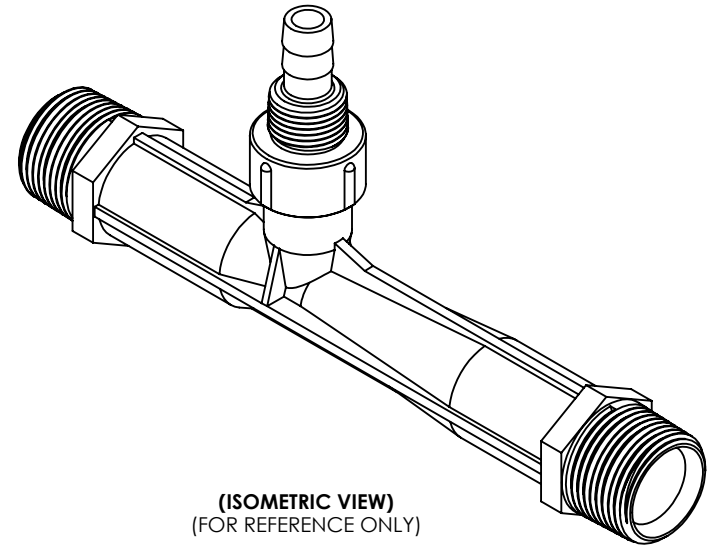

(ISOMETRIC VIEW)  
(FOR REFERENCE ONLY)

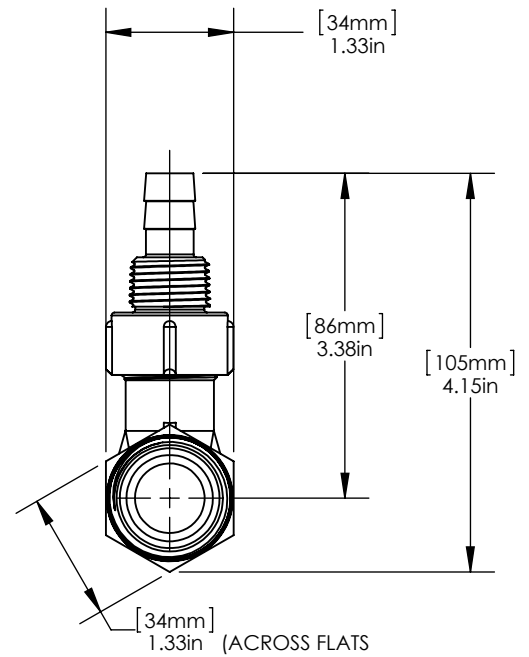
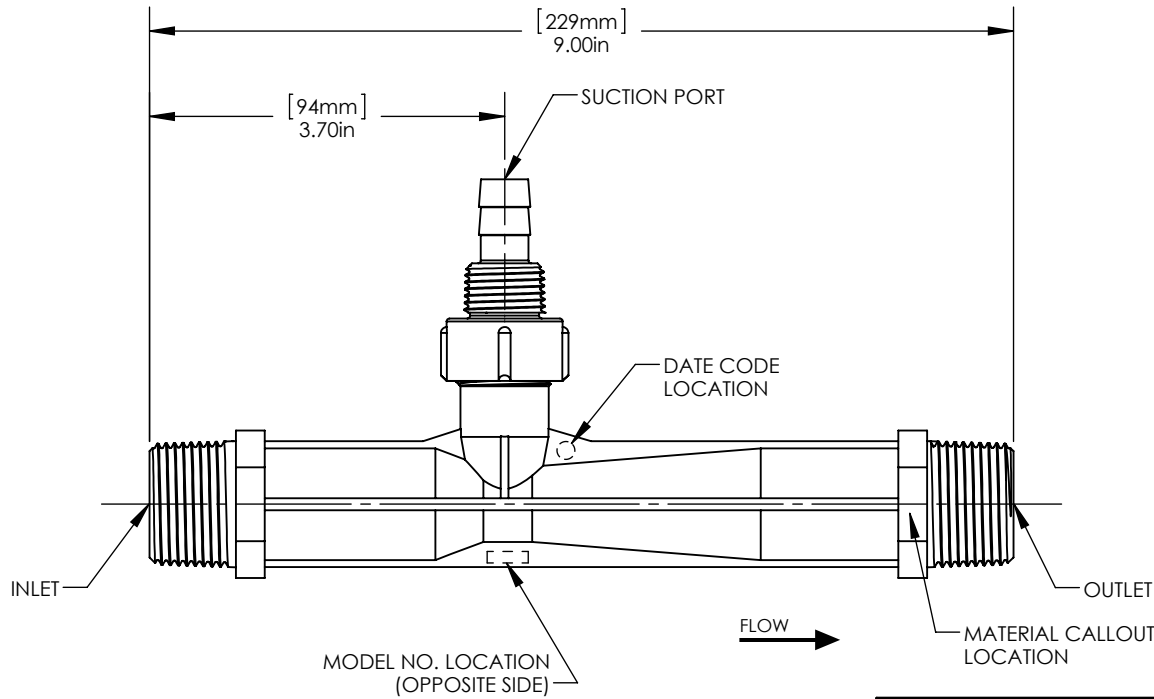

UNLESS OTHERWISE SPECIFIED DIMENSIONS ARE IN INCHES		 <b>Mazzei</b>	TITLE: 1" INJECTOR; MODEL 0878 3		
DRAWN: T. JOHNS	DATE: 7/19/2013		DRAWING NO.: 0878 3		
APPROVED: P. BANKOWSKI	SIZE: <b>A</b>	WEIGHT: N/A	SCALE: 1:2	REV.: B	SHEET: 2 OF 2