

NOTES:

1. MADE IN THE U.S.A.
2. U.S. PATENT No. 5,863,128
3. U.S. No. 3,852,076 AND INTERNATIONAL REGISTERED TRADEMARKS
4. MATERIAL: POLYVINYLIDENE FLUORIDE (PVDF) OR NATURAL POLYVINYLIDENE FLUORIDE (N-PVDF)
5. INLET/OUTLET CONNECTION:
3/4" MNPT OR BSPT
6. SUCTION PORT CONNECTION:

DEFAULT - 1/4" I.D. TUBING BARB WITH INTEGRATED CHECK VALVE

ALTERNATE - 1/4" MNPT - SEE ALTERNATE CAP MODIFICATION DETAIL
7. FOR INSTALLATION RECOMMENDATIONS REFER TO MAZZEI TECHNICAL BULLETINS No. 4, No. 5, No. 6, No. 10 AND No. 11, WHICH CAN BE FOUND AT WWW.MAZZEI.NET.
8. MAZZEI INJECTOR CO., LLC.
500 ROOSTER DR.
BAKERSFIELD, CA 93307
TEL: 661.363.6500
WEB: WWW.MAZZEI.NET

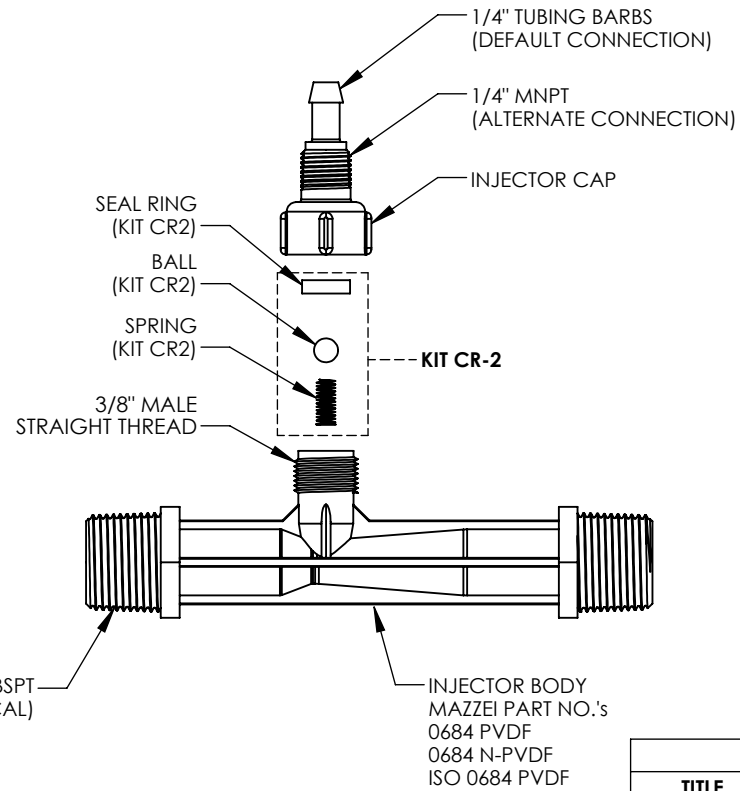

KIT CR-2	
TITLE	MATERIAL
BALL	TEFLON @ (PTFE)
SEAL RING	KEL-F @ (PCTFE)
SPRING	HASTELLOY C-22

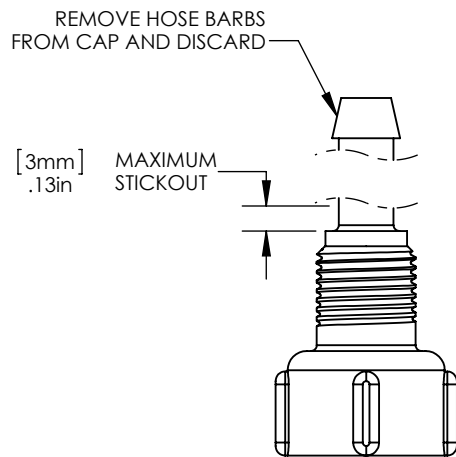

"CAP MODIFICATION DETAIL"
(ALTERNATE)

UNLESS OTHERWISE SPECIFIED DIMENSIONS ARE IN INCHES			TITLE: 3/4" INJECTOR; MODEL 0684		
DRAWN:	G. NOVINS		DRAWING NO.: 0684		
DATE:	7/17/2014	SIZE:	WEIGHT:	SCALE:	REV.:
APPROVED:	T. JOHNS	A	N/A	1:2	B
				SHEET:	1 OF 2

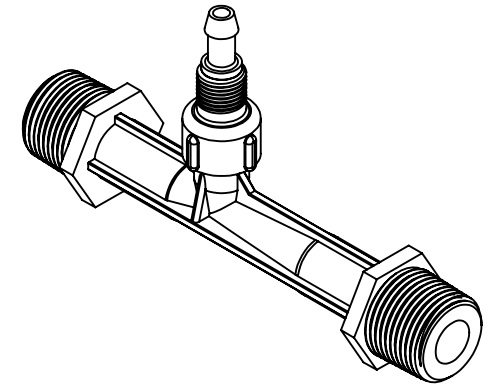

(ISOMETRIC VIEW)
(FOR REFERENCE ONLY)

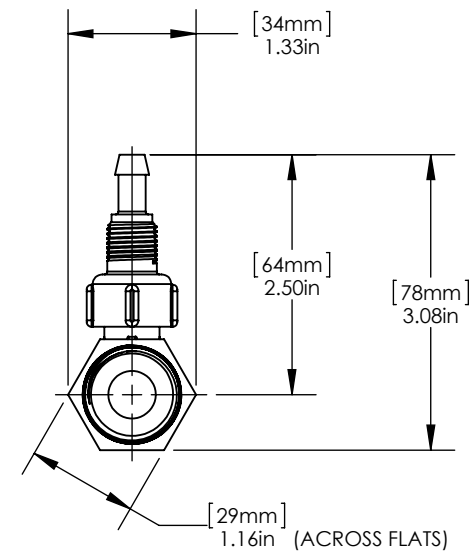
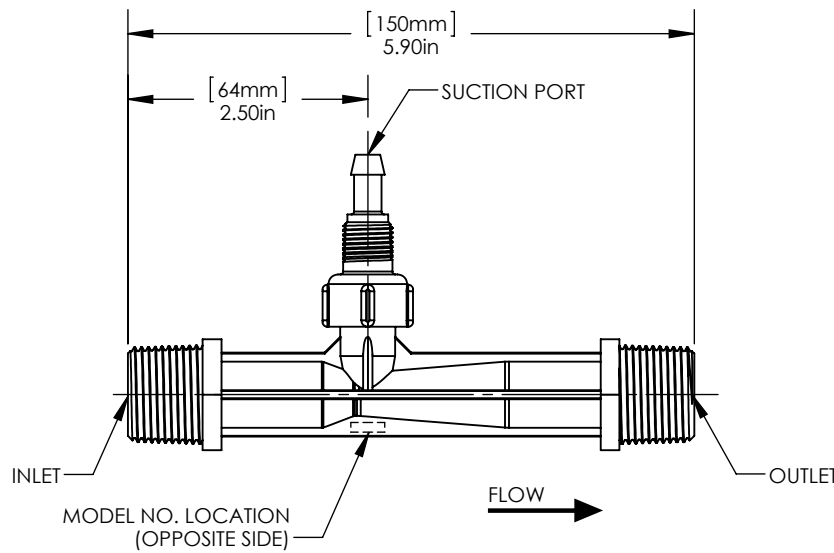

UNLESS OTHERWISE SPECIFIED DIMENSIONS ARE IN INCHES			TITLE: 3/4" INJECTOR; MODEL 0684		
DRAWN: G. NOVINS	DATE: 7/17/2014		DRAWING NO.: 0684		
APPROVED: T. JOHNS	SIZE: A	WEIGHT: N/A	SCALE: 1:2	REV.: B	SHEET: 2 OF 2