

NOTES:

1. MATERIAL(S) OF CONSTRUCTION:
 - A. BODY: STAINLESS STEEL, TYPE 316L (SCH. 40)
 - B. COVER: STAINLESS STEEL, GRADE CF8M
 - C. FLOAT & LINKAGE ASSEMBLIES: STAINLESS STEEL, TYPE 316L
 - D. ORIFICE BUTTON: KEL-F
 - E. HARDWARE: STAINLESS STEEL, TYPE 316L
 - F. GASKET: 1/16" THK. PTFE
2. PRIMARY CONNECTION TYPES(S):
 - A. INLET CONNECTION: 1.00 - MALE NATIONAL PIPE THREAD (MNPT); ANSI B1.20.1
 - B. OUTLET CONNECTION: 0.50 - FEMALE NATIONAL PIPE THREAD (FNPT); ANSI B1.20.1
3. APPROXIMATE WEIGHT(S):
 - A. EMPTY: 16 LBS (7.26 KGS)
4. PERFORMANCE DATA:
 - A. GAS RELEASE VALUES AS STATED BY MANUFACTURER, REFERENCE: http://www.valmatic.com/drawings/SS-461_3-4-13.pdf FOR FULL PERFORMANCE DATA RANGES.
 - B. ORIFICE DIAMETER: 5/16"
 - C. COLD WORKING PRESSURE:
 - i. MINIMUM: 5 PSIG (BELOW THIS VALUE, THE ORIFICE SEAT MAY NOT SEAL CORRECTLY CAUSING PREMATURE GAS/LIQUID RELEASES)
 - ii. MAXIMUM: 75 PSIG
5. PRODUCT FINISH:
 - A. PASSIVATED PER ASTM GUIDELINES
6. PRODUCT TESTING: (EITHER OPTION IS CHOSEN AT MAZZEI'S DISCRETION)
 - A. HYDROSTATIC TEST PRESSURE: 1.5X CWP OR 150 PSIG (WHICHEVER IS GREATER)
 - B. DYE PENETRANT TESTING PER ASME B31.3, NORMAL SERVICE, GUIDELINES
7. MISCELLANEOUS:
 - A. VALVE IS DESIGNED AND ENGINEERED BY OTHERS

REVISIONS			
REV.	DESCRIPTION	DATE	APPROVED
A	RELEASED FOR SUBMITTAL.	5/4/18	J. BENNETT

APPROVED
RELEASED FOR SUBMITTAL

EQUIPMENT NAMEPLATE
(NOT SHOWN FOR CLARITY)

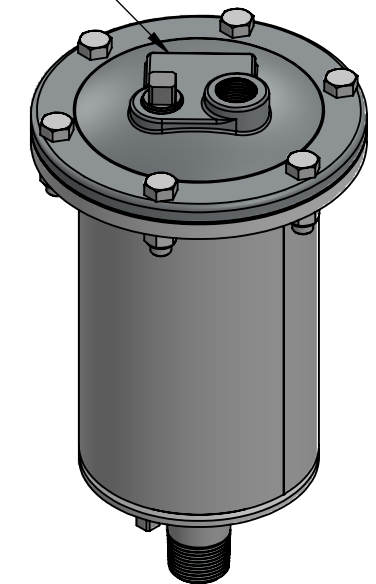

ISOMETRIC VIEW

SUBMITTAL DRAWING

SUBMITTAL NOTICE	CONFIDENTIALITY NOTICE	UNLESS OTHERWISE SPECIFIED DIM ARE IN INCHES TOL ON ANGLE $\pm .50^\circ$ 2 PL $\pm .06$ 3 PL $\pm .030$ INTERPRET DIM AND TOL PER ASME Y14.5M-1994	APPROVALS	DATE		MAZZEI INJECTOR CO., LLC			
ANY RECOMMENDATIONS FOR PRODUCT AND/OR SYSTEM DESIGN, WHETHER CONTAINED IN A DOCUMENT, WITHIN THIS DRAWING, COMMUNICATED BY ELECTRONIC MEANS OR GIVEN VERBALLY, ARE INTENDED SOLELY AS GUIDELINES TO ACTUAL SYSTEM DESIGN. SAID RECOMMENDATIONS ARE BASED UPON INFORMATION SUPPLIED BY OTHERS, THE ACCURACY OF WHICH IS BEYOND VERIFICATION BY MAZZEI INJECTOR CO., LLC. THEREFOR MAZZEI CANNOT AND DOES NOT WARRANT THE SUITABILITY OF ITS PRODUCTS FOR A PARTICULAR SERVICE NOR THE PERFORMANCE OF ANY SYSTEM CONTAINING COMPONENTS MADE OR SOLD BY MAZZEI.	THE INFORMATION CONTAINED IN THIS DRAWING IS THE SOLE PROPERTY OF MAZZEI INJECTOR COMPANY LLC. ANY REPRODUCTION IN PART OR AS A WHOLE WITHOUT THE WRITTEN PERMISSION OF MAZZEI IS STRICTLY PROHIBITED.	THIRD ANGLE PROJECTION	DRAWN: J. MARASIGAN	4/3/2018		500 ROOSTER DRIVE BAKERSFIELD, CA 93307 PHONE: (661) 363-6500 FAX: (661)363-7500 WWW.MAZZEI.NET			
			CHECKED: F. FLORES	5/4/2018	DEGAS RELIEF VALVE				
			APPROVED: J. BENNETT	5/4/2018	QA: -	CUSTOMER APPROVAL: -	CUSTOMER: NA	SIZE: B	JOB NO.: NA
DRAWING MAY NOT BE PRINTED FULL SIZE DO NOT SCALE					SCALE: NONE	WEIGHT: 16 LBS	SHEET: 1 OF 3		

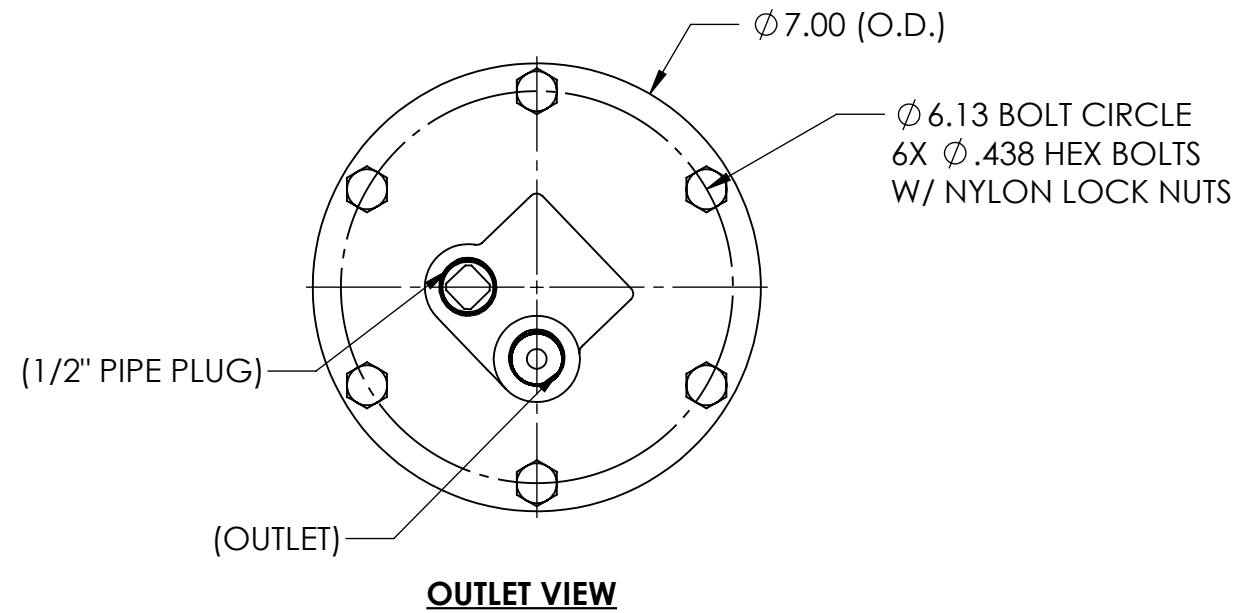
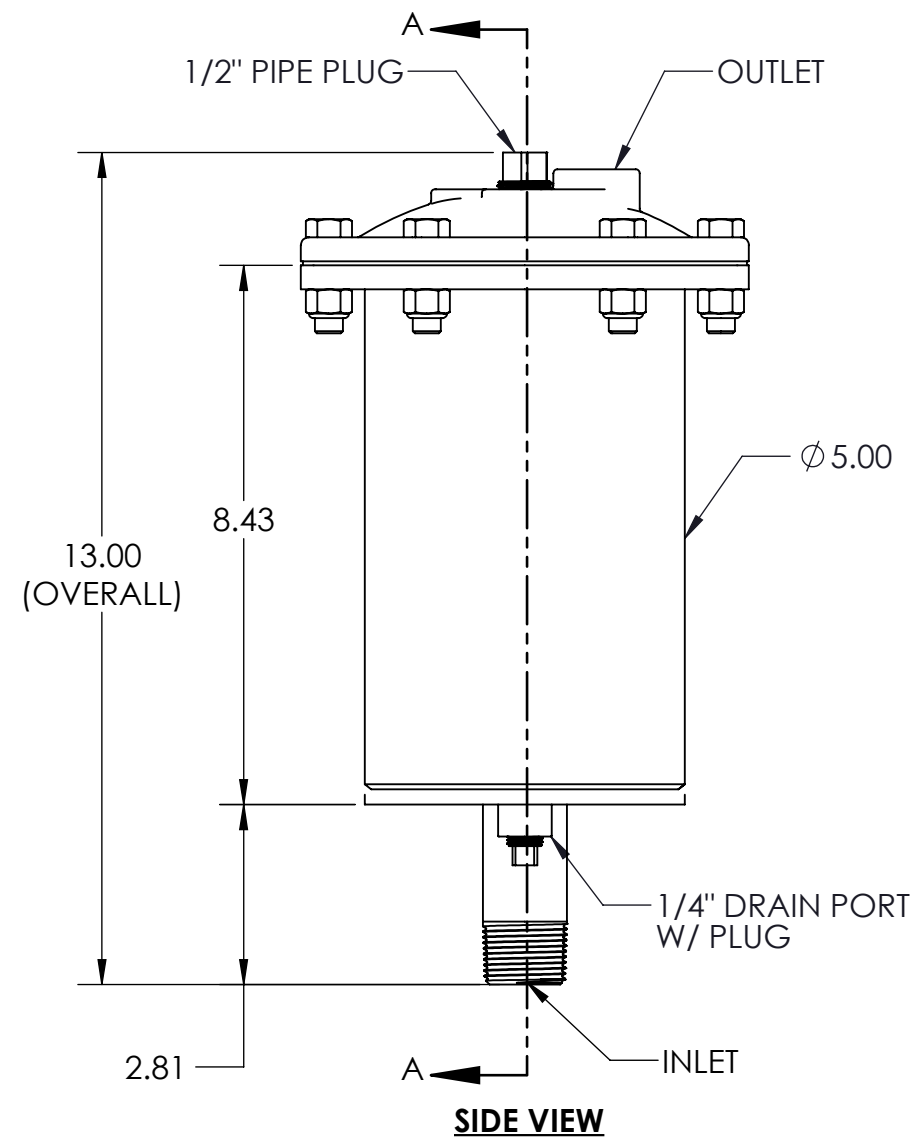

APPROVED
RELEASED FOR SUBMITTAL

		MAZZEI INJECTOR CO., LLC 500 ROOSTER DRIVE BAKERSFIELD, CA 93307 PHONE: (661) 363-6500 FAX: (661)363-7500 WWW.MAZZEI.NET	
		TITLE: DEGAS RELIEF VALVE	
SIZE: B	JOB NO.: NA	DRAWING NUMBER: DRV38FEACF00-SUB	REV: A
SCALE: 1:3	WEIGHT: 16 LBS	SHEET: 2 OF 3	

NOTES:

1. PARTS LISTED BELOW PROVIDE COMMON PARTS WHICH NEED REPLACING, USUALLY FROM WEAR AND TEAR. IF ADDITIONAL SPARE PARTS ARE REQUIRED, BEYOND WHAT IS OFFERED, A WHOLE UNITE PROCUREMENT IS REQUIRED.
2. THE CONTENTS OF THE SPARE PARTS KIT CAN VARY FROM MODEL TO MODEL AND CAN CHANGE WITHOUT NOTICE.

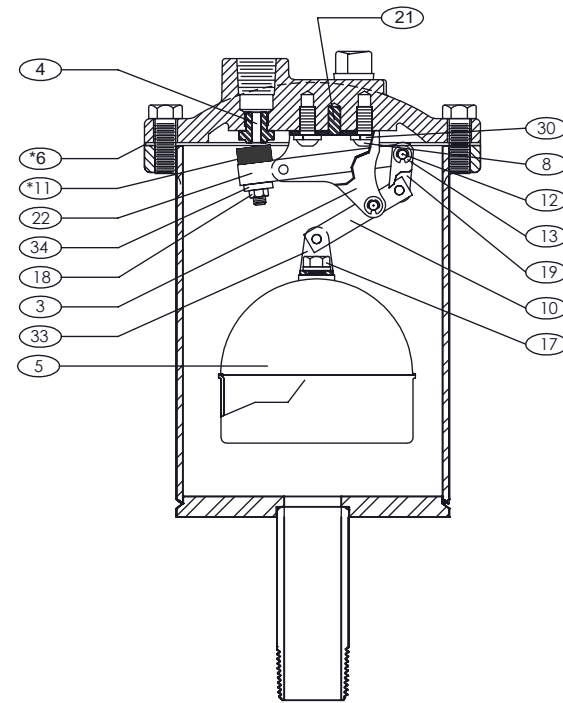

SECTION A-A
(SEE SHEET 2)

SPARE PARTS KIT (COMPLETE)

MAZZEI PN# DRV38/48CVR&FLT

2 COVER	17 FLOAT RETAINER
3 LEVER FRAME	18 LOCK NUT
4 SEAT	19 LINK
5 FLOAT	20 EXTENSION SHAFT
6 GASKET	21 LOCATING PIN
8 RETAINING SCREW	22 ORIFICE BUTTON ARM
10 FLOAT ARM	30 LOCK WASHER
11 ORIFICE BUTTON	33 CLEVIS
12 PIVOT PIN	34 LOCK WASHER
13 RETAINING RING	

REFERENCE: (VAL-MATIC PN# SPK1-48AX038)

NOTE: CUSTOMER TO SPECIFY WHICH CWP (75 OR 150)
AT TIME OF ORDER

SPARE PARTS KIT (PARTIAL)

MAZZEI PN# SPK1-48A

3 LEVER FRAME	17 FLOAT RETAINER
4 SEAT	18 LOCK NUT
5 FLOAT	19 LINK
6 GASKET	20 EXTENSION SHAFT
8 RETAINING SCREW	21 LOCATING PIN
10 FLOAT ARM	22 ORIFICE BUTTON ARM
11 ORIFICE BUTTON	30 LOCK WASHER
12 PIVOT PIN	33 CLEVIS
13 RETAINING RING	34 LOCK WASHER

REFERENCE: (VAL-MATIC PN# SPK1-48AX001)

NOTE: CUSTOMER TO SPECIFY WHICH CWP (75 OR 150)
AT TIME OF ORDER

SPARE PARTS KIT (MISC.)

MAZZEI PN# DRV38/48GSKT-M

6 GASKET

REFERENCE: (VAL-MATIC PN# P101-6)

SPARE PARTS KIT (MISC.)

MAZZEI PN# DRV38/48BUTN-O

11 ORIFICE BUTTON

REFERENCE: (VAL-MATIC PN# A201C-11X001)

APPROVED
RELEASED FOR SUBMITTAL

	MAZZEI INJECTOR CO., LLC 500 ROOSTER DRIVE BAKERSFIELD, CA 93307 PHONE: (661) 363-6500 FAX: (661)363-7500 WWW.MAZZEI.NET		
	TITLE: DEGAS RELIEF VALVE		
SIZE: B	JOB NO.: NA	DRAWING NUMBER: DRV38FEACF00-SUB	REV: A
SCALE: NONE	WEIGHT: 16 LBS	SHEET: 3 OF 3	