

NOTES:

1. MADE IN THE U.S.A.
2. U.S. PATENT No. 5,863,128
3. U.S. No. 3,852,076 AND INTERNATIONAL REGISTERED TRADEMARKS
4. MATERIAL: GLASS FILLED POLYPROPYLENE (PP) OR POLYVINYLIDENE FLUORIDE (PVDF) OR NATURAL POLYVINYLIDENE FLUORIDE (N-PVDF)
5. INLET/OUTLET CONNECTION:
1" MNPT OR BSPT
6. SUCTION PORT CONNECTION:

DEFAULT - 1/2" I.D. TUBING BARB WITH INTEGRATED CHECK VALVE

ALTERNATE - 1/2" MNPT - SEE ALTERNATE CAP MODIFICATION DETAIL
7. FOR INSTALLATION RECOMMENDATIONS REFER TO MAZZEI TECHNICAL BULLETINS No. 4, No. 5, No. 6, No. 10 AND No. 11, WHICH CAN BE FOUND AT WWW.MAZZEI.NET.
8. MAZZEI INJECTOR CO., LLC.
500 ROOSTER DR.
BAKERSFIELD, CA 93307
TEL: 661.363.6500
WEB: WWW.MAZZEI.NET

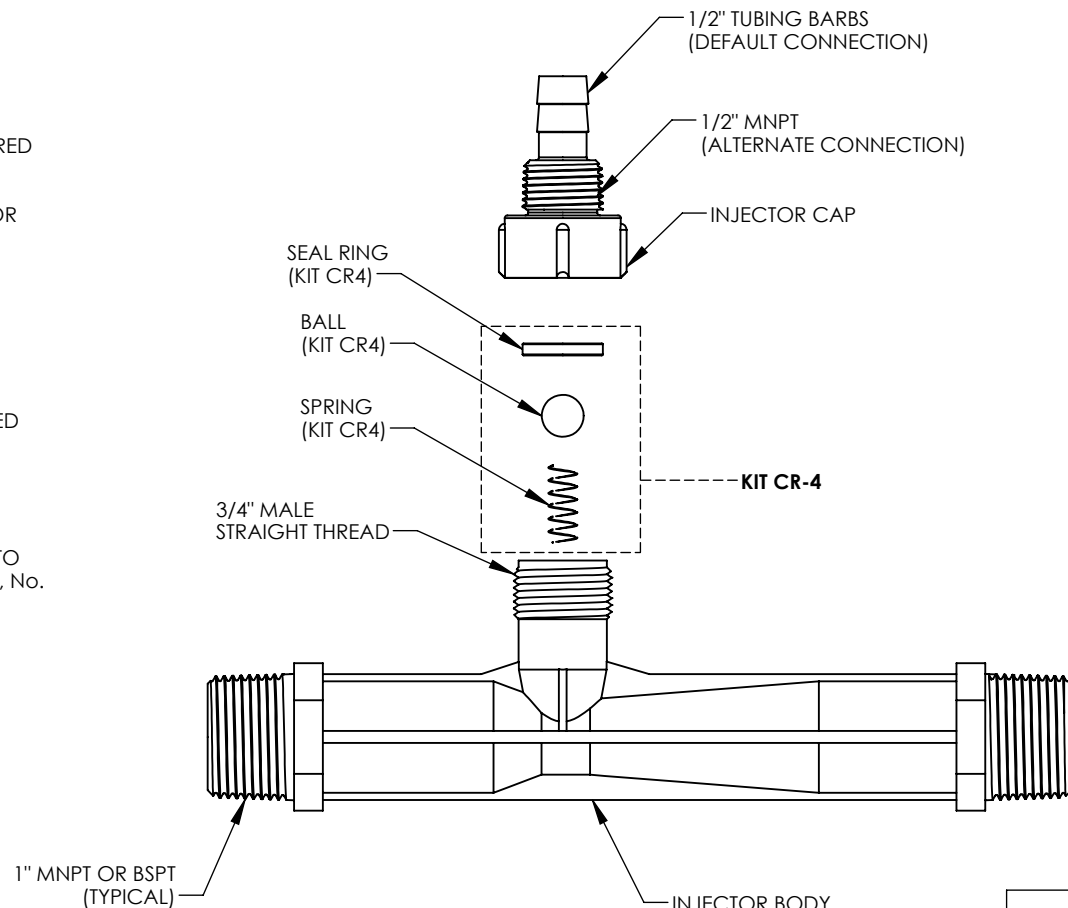

REMOVE HOSE BARBS FROM CAP AND DISCARD

[3mm]
0.13in
MAXIMUM
STICKOUT

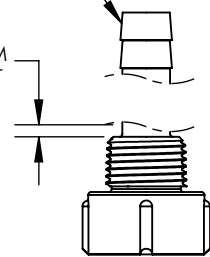

"CAP MODIFICATION DETAIL"
(ALTERNATE)

INJECTOR BODY
MAZZEI PART NO.'S
0878 3 PP
0878 3 PVDF
0878 3 N-PVDF
ISO 0878 3 GRPP
ISO 0878 3 PVDF

KIT CR-4	
TITLE	MATERIAL
BALL	TEFLON @ (PTFE)
SEAL RING	KEL-F @ (PCTFE)
SPRING	HASTELLOY C-22

UNLESS OTHERWISE SPECIFIED DIMENSIONS ARE IN INCHES			TITLE: 1" INJECTOR; MODEL 0878 3		
DRAWN: T. JOHNS	DATE: 7/19/2013		DRAWING NO.: 0878 3		
APPROVED: P. BANKOWSKI	SIZE: A	WEIGHT: N/A	SCALE: 1:2	REV.: B	SHEET: 1 OF 2

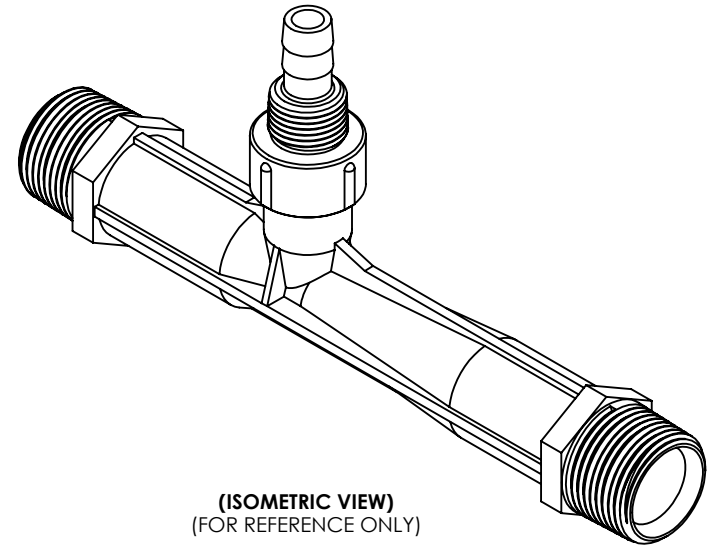

(ISOMETRIC VIEW)
(FOR REFERENCE ONLY)

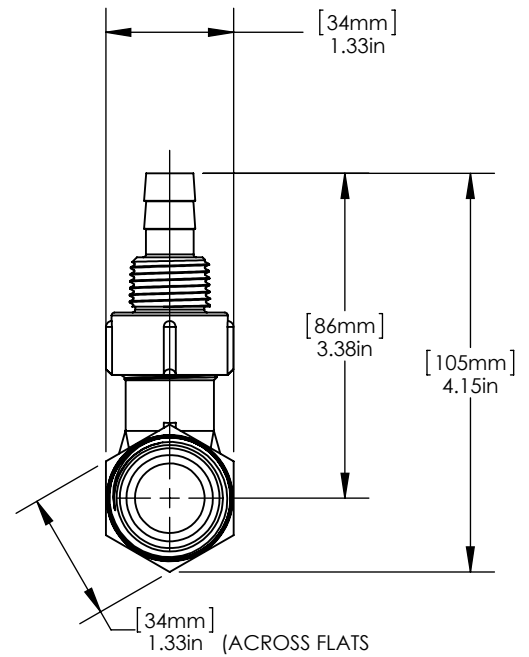
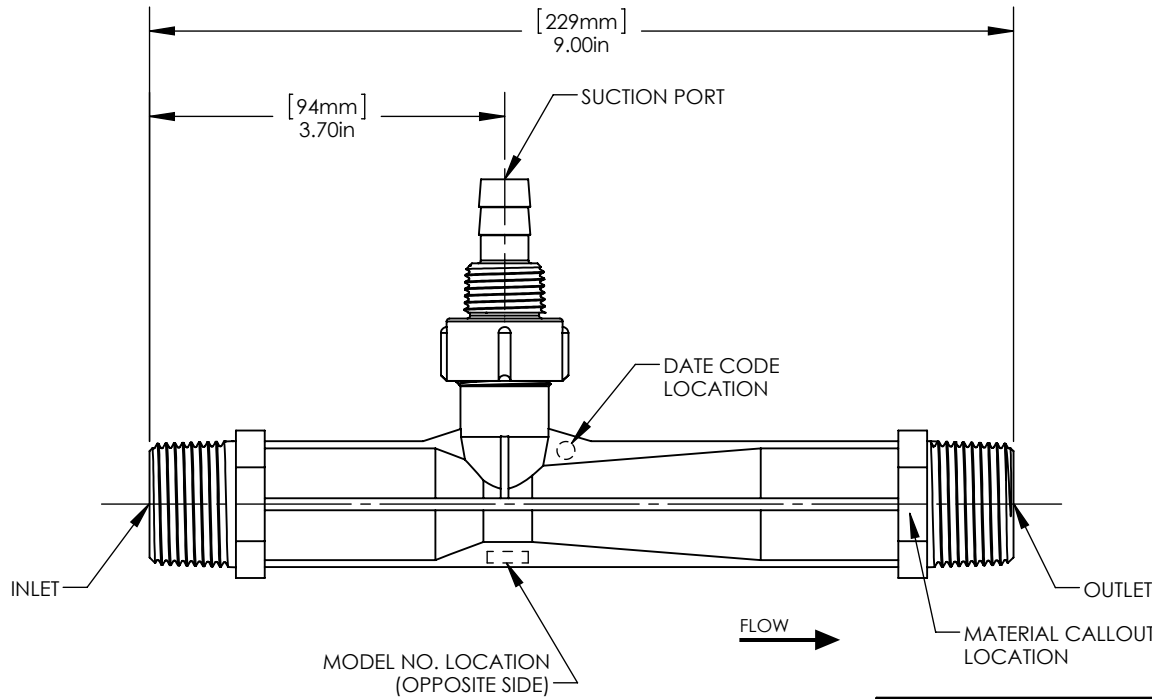

UNLESS OTHERWISE SPECIFIED DIMENSIONS ARE IN INCHES			TITLE: 1" INJECTOR; MODEL 0878 3		
DRAWN: T. JOHNS	DATE: 7/19/2013		DRAWING NO.: 0878 3		
APPROVED: P. BANKOWSKI	SIZE: A	WEIGHT: N/A	SCALE: 1:2	REV.: B	SHEET: 2 OF 2



Tabla de Rendimiento de Inyectores
Capacidad de Succión de Agua

Presión Operacional PSIG		Succión de Agua		Presión Operacional PSIG		Succión de Agua	
ENTRADA del Inyector	SALIDA del Inyector	Flujo de la Línea Principal GPM	Succión de Agua GPH	ENTRADA del Inyector	SALIDA del Inyector	Flujo de la Línea Principal GPM	Succión de Agua GPH
5	0	3.6	62.8	60	0	12.6	72.4
	1		36.1		5		72.4
	2		23.8		10		72.4
	3		7.3		15		72.4
	4		*(4.1)		1.6		20
10	0	5.2	93.7		30		71.2
	2		61.9		35		63.3
	5		36.4		40		41.4
	7		15.8		45		*(51.2)
	8		*(8.7)		3.7		0
15	0	6.3	87.3	70	5	13.7	73.6
	5		62.1		10		73.6
	7		45.4		15		73.6
	10		23.6		20		73.6
	12		*(12.5)		7.2		30
20	0	7.3	82.8		40		67.5
	5		80.4		45		46.9
	10		48.6		50		30.7
	12		33.6		55		*(58.3)
	15		*(16.5)		21.0		0
25	0	8.2	82.3	80	5	14.6	74.2
	5		81.3		10		74.2
	10		73.2		15		74.2
	15		45.3		20		74.2
	20		*(21.0)		20.1		30
30	0	8.9	79.9		40		73.7
	5		79.1		50		56.9
	10		76.9		60		25.8
	15		65.3		65		*(67.5)
	20		35.3		9.0		0
35	0	9.7	79.3	90	5	15.5	74.2
	5		79.3		10		74.2
	10		77.5		20		74.2
	15		74.5		30		74.2
	20		52.3		40		74.2
40	0	10.3	77.4		50		70.0
	5		77.4		60		47.8
	10		77.4		70		18.1
	15		73.6		75		*(75.6)
	20		50.6		0.84		0
45	0	11.0	79.6	100	5	16.3	76.3
	5		79.6		10		76.3
	10		79.6		20		76.3
	15		79.6		30		76.3
	20		78.8		40		76.3
50	0	11.5	74.7		50		74.5
	5		74.7		60		67.7
	10		74.7		70		44.6
	15		74.7		80		*(84.5)
	20		74.7		0		75.3
55	0	11.5	74.7	120	5	17.9	75.3
	5		74.7		10		75.3
	10		74.7		20		75.3
	15		74.7		30		75.3
	20		74.7		40		75.3
	25		68.3		50		75.3
	30		56.1		60		74.9
	35		36.6		70		70.2
40	*(42.3)	9.5	80		61.2		
55	0	11.5	9.5		90		34.5
	5		9.5	100	*(101)		

Derechos de Autor © 2015 REV.07.2015

Mazzei Injector Company, LLC
500 Rooster Drive, Bakersfield, CA 93307-9555 USA

TEL 661.363.6500 • FAX 661.363.7500 • www.mazzei.net

* Los números entre paréntesis indican la presión de salida del inyector cuando deja de aspirar (punto cero de succión).

Modelo 0878-03



Tabla de Rendimiento de Inyectores
Capacidad de Succión de Agua - MÉTRICO

Presión Operacional kg/cm ²		Succión de Agua		Presión Operacional kg/cm ²		Succión de Agua		
ENTRADA del Inyector	SALIDA del Inyector	Flujo de la Línea Principal l/min	Succión de Agua l/hr	ENTRADA del Inyector	SALIDA del Inyector	Flujo de la Línea Principal l/min	Succión de Agua l/hr	
0.35	0.00	13.8	237	4.22	0.00	47.9	274	
	0.07		136		0.35		274	
	0.14		90.2		0.70		274	
	0.21		27.7		1.05		274	
	0.28		*(0.28)		1.41		274	
0.70	0.00	19.5	354		2.11		269	
	0.14		234		2.46		239	
	0.35		138		2.81		156	
	0.49		59.9		3.16		*(3.60)	61.8
	0.56		*(0.61)		14.0			
1.05	0.00	23.9	330	4.92	0.00	51.7	278	
	0.35		235		0.35		278	
	0.49		172		0.70		278	
	0.70		89.4		1.05		278	
	0.84		*(0.88)		1.41		278	
1.41	0.00	27.6	313		2.11		278	
	0.35		304		2.81		255	
	0.70		184		3.16		177	
	0.84		127		3.52		116	
	1.05		*(1.16)		3.87		*(4.10)	48.8
1.76	0.00	30.9	311	5.62	0.00	55.3	280	
	0.35		307		0.35		280	
	0.70		277		0.70		280	
	1.05		171		1.05		280	
	1.41		*(1.48)		1.41		280	
2.11	0.00	33.9	302		2.11		280	
	0.35		299		2.81		278	
	0.70		291		3.52		215	
	1.05		247		4.22		97.7	
	1.41		133		4.57		*(4.75)	30.0
2.46	0.00	36.6	300	6.33	0.00	58.7	281	
	0.35		300		0.35		281	
	0.70		293		0.70		281	
	1.05		282		1.41		281	
	1.41		198		2.11		281	
2.81	0.00	39.1	293		2.81		281	
	0.35		293		3.52		265	
	0.70		293		4.22		181	
	1.05		293		4.92		68.7	
	1.41		278		5.27		*(5.32)	3.1
3.16	0.00	41.5	293	7.03	0.00	61.8	289	
	0.35		293		0.35		289	
	0.70		301		0.70		289	
	1.05		301		1.41		289	
	1.41		298		2.11		289	
3.52	0.00	43.7	301		2.81		289	
	0.35		283		3.52		281	
	0.70		283		4.22		256	
	1.05		283		4.92		169	
	1.41		283		5.62		*(5.94)	49.2
3.52	0.00	43.7	283	8.44	0.00	67.7	285	
	0.35		283		0.35		285	
	0.70		283		0.70		285	
	1.05		283		1.41		285	
	1.41		283		2.11		285	
3.52	0.00	43.7	283		2.81		285	
	0.35		283		3.52		285	
	0.70		283		4.22		285	
	1.05		283		4.92		266	
	1.41		283		5.62		231	
3.52	0.00	43.7	283	6.33	130			
	0.35		283	7.03	*(7.14)	32.5		
	0.70		283					
	1.05		283					
	1.41		283					

Modelo 0878-03

Derechos de Autor © 2015 REV07.2015

Mazzei Injector Company, LLC
500 Rooster Drive, Bakersfield, CA 93307-9555 USA

TEL 661.363.6500 • FAX 661.363.7500 • www.mazzei.net

* Los números entre paréntesis indican la presión de salida del inyector cuando deja de aspirar (punto cero de succión).



Presión Operacional PSIG		Succión de Aire		Presión Operacional PSIG		Succión de Aire	
ENTRADA del Inyector	SALIDA del Inyector	Flujo de la Línea Principal GPM	Succión de Aire SCFH	ENTRADA del Inyector	SALIDA del Inyector	Flujo de la Línea Principal GPM	Succión de Aire SCFH
5	0	3.5	14.9	60	0	12.1	71.3
	1		5.4		5		54.9
	2		1.5		10		33.4
	3		0.41		15		20.2
	4		*(4.0)		20		14.6
10	0	4.9	33.9		30		7.8
	2		8.5		35		5.7
	5		2.8		40		4.3
	7		0.88		45		*(51.2)
	8		*(8.7)		0.61		2.4
15	0	6.1	36.0	70	0	13.1	77.0
	5		7.4		5		60.1
	7		3.8		10		40.7
	10		0.74		15		25.5
	12		*(12.5)		20		19.1
20	0	7.0	44.2		30		11.2
	5		12.5		40		6.7
	10		4.3		45		5.0
	12		2.7		50		4.1
	15		*(16.5)		1.7		*(58.3)
25	0	7.8	44.7	80	0	14.0	81.2
	5		17.4		5		65.0
	10		6.7		10		49.9
	15		3.4		15		31.0
	20		*(21.0)		1.2		23.1
30	0	8.6	51.0		30		14.1
	5		26.1		40		9.0
	10		11.3		50		5.8
	15		6.4		60		3.8
	20		2.9		65		*(67.5)
35	0	9.3	51.9	90	0	14.8	85.3
	5		34.3		5		69.6
	10		14.0		10		56.4
	15		8.6		20		26.9
	20		4.7		30		17.3
40	0	9.9	55.8		40		12.1
	5		40.6		50		7.9
	10		17.6		60		5.1
	15		11.6		70		3.4
	20		6.6		75		*(75.6)
45	0	10.5	66.9	100	0	15.6	88.6
	5		42.1		5		72.4
	10		20.7		10		62.8
	15		12.8		20		30.9
	20		8.9		30		20.3
50	0	11.1	64.9		40		14.5
	5		48.7		50		10.0
	10		23.8		60		7.2
	15		16.1		70		5.1
	20		10.3		80		*(84.5)
60	0	12.1	71.3	120	0	17.1	98.1
	5		54.9		5		81.0
	10		33.4		10		70.8
	15		20.2		20		41.9
	20		14.6		30		26.1
	30		7.8		40		19.2
	35		5.7		50		14.5
	40		4.3		60		10.8
45	*(51.2)	70	7.8				
0	13.1	77.0	80		5.7		
5		60.1	90	4.6			
10		40.7	100	*(101)			
15		25.5	2.5				
20		19.1					
30		11.2					
40		6.7					
45		5.0					
50	4.1						
55	*(58.3)						
0	14.0	81.2					
5		65.0					
10		49.9					
15		31.0					
20		23.1					
30		14.1					
40		9.0					
50		5.8					
60	3.8						
65	*(67.5)						
0	14.8	85.3					
5		69.6					
10		56.4					
20		26.9					
30		17.3					
40		12.1					
50		7.9					
60		5.1					
70	3.4						
75	*(75.6)						
0	15.6	88.6					
5		72.4					
10		62.8					
20		30.9					
30		20.3					
40		14.5					
50		10.0					
60		7.2					
70	5.1						
80	*(84.5)						
0	17.1	98.1					
5		81.0					
10		70.8					
20		41.9					
30		26.1					
40		19.2					
50		14.5					
60		10.8					
70	7.8						
80	5.7						
90	4.6						
100	*(101)						

Tabla de Rendimiento de Inyectores
Capacidad de Succión de Aire

Modelo 0878-03

Derechos de Autor © 2015 REV.07.2015

Mazzei Injector Company, LLC
500 Rooster Drive, Bakersfield, CA 93307-9555 USA

TEL 661.363.6500 • FAX 661.363.7500 • www.mazzei.net

* Los números entre paréntesis indican la presión de salida del inyector cuando deja de aspirar (punto cero de succión).



Tabla de Rendimiento de Inyectores
Capacidad de Succión de Aire - MÉTRICO

Presión Operacional kg/cm ²		Succión de Aire		Presión Operacional kg/cm ²		Succión de Aire	
ENTRADA del Inyector	SALIDA del Inyector	Flujo de la Línea Principal l/min	Succión de Aire l/min	ENTRADA del Inyector	SALIDA del Inyector	Flujo de la Línea Principal l/min	Succión de Aire l/min
0.35	0.00	13.2	7.0	4.22	0.00	45.9	33.6
	0.07		2.5		0.35		25.9
	0.14		0.73		0.70		15.8
	0.21		0.19		1.05		9.5
	0.28		*(0.28)		1.41		6.9
0.70	0.00	18.7	16.0		2.11		3.6
	0.14		4.0		2.46		2.7
	0.35		1.3		2.81		2.0
	0.49		0.42		3.16		1.1
	0.56		*(0.61)		0.29		*(3.60)
1.05	0.00	22.9	17.0	4.92	0.00	49.6	36.3
	0.35		3.5		0.35		28.3
	0.49		1.8		0.70		19.2
	0.70		0.35		1.05		12.0
	0.84		*(0.88)		1.41		9.0
1.41	0.00	26.5	20.9		2.11		5.3
	0.35		5.9		2.81		3.2
	0.70		2.0		3.16		2.3
	0.84		1.2		3.52		1.9
	1.05		*(1.16)		3.87		1.0
1.76	0.00	29.6	21.1	5.62	0.00	53.0	38.3
	0.35		8.2		0.35		30.6
	0.70		3.2		0.70		23.5
	1.05		1.6		1.05		14.6
	1.41		*(1.48)		1.41		10.9
2.11	0.00	32.5	24.0		2.11		6.6
	0.35		12.3		2.81		4.2
	0.70		5.3		3.52		2.7
	1.05		3.0		4.22		1.8
	1.41		1.4		4.57		1.1
2.46	0.00	35.1	24.5	6.33	0.00	56.2	40.2
	0.35		16.2		0.35		32.8
	0.70		6.6		0.70		26.6
	1.05		4.0		1.41		12.7
	1.41		2.2		2.11		8.1
2.81	0.00	37.5	26.3		2.81		5.7
	0.35		19.1		3.52		3.7
	0.70		8.3		4.22		2.4
	1.05		5.5		4.92		1.6
	1.41		3.1		5.27		1.0
3.16	0.00	39.7	31.5	7.03	0.00	59.3	41.85
	0.35		19.9		0.35		34.1
	0.70		9.8		0.70		29.6
	1.05		6.0		1.41		14.6
	1.41		4.2		2.11		9.5
3.52	0.00	41.9	30.6		2.81		6.8
	0.35		23.0		3.52		4.7
	0.70		11.2		4.22		3.4
	1.05		7.6		4.92		2.4
	1.41		4.9		5.62		1.3
3.52	1.76	41.9	3.9	8.44	0.00	64.9	46.3
	2.11		1.9		0.35		38.2
	2.46		1.0		0.70		33.4
	2.81		*(2.97)		1.41		19.7
					2.11		12.3
					2.81		9.0
					3.52		6.8
					4.22		5.1
		4.92	3.7				
		5.62	2.7				
		6.33	2.1				
		7.03	1.1				

* Los números entre paréntesis indican la presión de salida del inyector cuando deja de aspirar (punto cero de succión).