

NOTES:

1. MATERIAL OF CONSTRUCTION: TYPE 316L, STAINLESS STEEL
2. MTR/HEAT NUMBERS ARE PROVIDED FOR ALL MATERIALS AND SHALL MEET APPLICABLE MATERIAL SPECIFICATIONS.
3. MAXIMUM PRESSURE: 150 PSI (10.34 BAR)
4. MAXIMUM OPERATING TEMPERATURE: 180°F (82.2°C)
5. PRESSURE LOSS: 1 - 4 PSID (.07 - .28 BAR) AT RATED FLOW
6. RATED FLOW: 100 - 300 GPM (22.7 - 68.1 M<sup>3</sup>/HR)
7. EMPTY WEIGHT (DRY): APPROXIMATELY 56 LBS. (26 KG)
8. WATER VOLUME: 10 GALLONS (36.7 LITERS)
9. INLET/OUTLET CONNECTION:  
3.00" DIA., ANSI B1.20.1, MALE NATIONAL PIPE THREAD (MNPT)
10. VENT CONNECTION:  
1.50" DIA., ANSI B1.20.1, FEMALE NATIONAL PIPE THREAD (FNPT)
11. FINISH: GLASS BLAST EXTERIOR ONLY
12. HYDROSTATICALLY TESTED TO 80 PSIG (5.5 BAR)
13. WELDING JOINTS TO BE COMPLETE PENETRATION, WHERE POSSIBLE.
14. DYE PENETRANT TESTING IN ACCORDANCE WITH ASME B31.3 NORMAL SERVICE RECOMMENDATIONS WILL BE PERFORMED ON A MINIMUM OF 20% OF LINEAR LENGTH OF WELDS; OR HYDROSTATIC TESTING WILL BE PERFORMED AS PART OF MAZZEI'S NON-DESTRUCTIVE TESTING PROCEDURE.
15. CLEANED FOR PASSIVATION PER ASTM A380 GUIDELINES.
16. PASSIVATED PER ASTM A967 SPECIFICATION.
17. WELD MAP, NON DESTRUCTIVE TESTING (NDT), CLEANING AND INSPECTION REPORTS TO BE PROVIDED BY MAZZEI.
18. MAZZEI RECOMMENDS INSTALLING THE DEGAS SEPARATOR PER THE O&M MANUAL GUIDELINES.

| REVISIONS |                         |            |              |
|-----------|-------------------------|------------|--------------|
| REV.      | DESCRIPTION             | DATE       | APPROVED     |
| NC        | RELEASED FOR SUBMITTAL. | 11/28/2012 | P. BANKOWSKI |
| A         | UPDATED STANDARD NOTES. | 7/21/2013  | P. BANKOWSKI |
| B         | REVISED NOTE 4          | 9/10/2015  | J. BENNETT   |

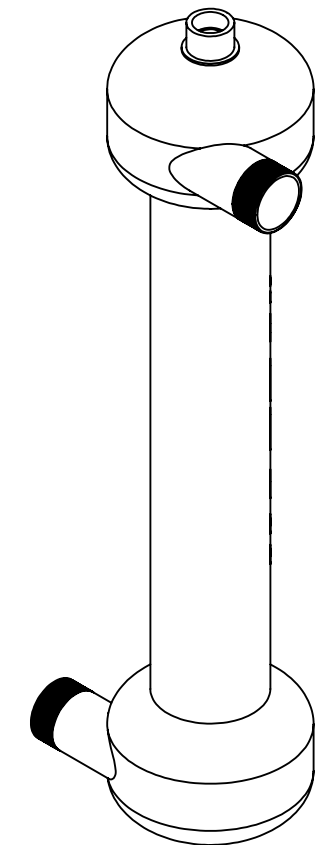

(ISOMETRIC VIEW)  
(FOR REFERENCE ONLY)

**SUBMITTAL DRAWING**

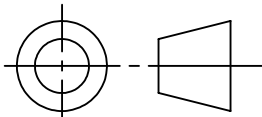
|   |  |  |  |   |  |                          |  |                 |  |  |  |                                |  |                      |  |
|---|--|--|--|---|--|--------------------------|--|-----------------|--|--|--|--------------------------------|--|----------------------|--|
| <b>SUBMITTAL NOTICE</b>   |  | <b>CONFIDENTIALITY NOTICE</b>  |  | UNLESS OTHERWISE SPECIFIED<br>DIM ARE IN INCHES<br>TOL ON ANGLE ± .1/2°<br>1 PL ± .125 2 PL ± .060 3 PL ± .030<br>INTERPRET DIM AND TOL PER<br>ASME Y14.5M-1994 |  | APPROVALS                |  | DATE            |  |  <b>MAZZEI INJECTOR CO., LLC</b><br>500 ROOSTER DRIVE BAKERSFIELD, CA 93307<br>PHONE: (661) 363-6500 FAX: (661)363-7500<br>WWW.MAZZEI.NET |  |                                |  |                      |  |
| ANY RECOMMENDATIONS FOR PRODUCT AND/OR SYSTEM DESIGN, WHETHER CONTAINED IN A DOCUMENT, WITHIN THIS DRAWING, COMMUNICATED BY ELECTRONIC MEANS OR GIVEN VERBALLY, ARE INTENDED SOLELY AS GUIDELINES TO ACTUAL SYSTEM DESIGN. SAID RECOMMENDATIONS ARE BASED UPON INFORMATION SUPPLIED BY OTHERS, THE ACCURACY OF WHICH IS BEYOND VERIFICATION BY MAZZEI INJECTOR CO., LLC. THEREFOR MAZZEI CANNOT AND DOES NOT WARRANT THE SUITABILITY OF ITS PRODUCTS FOR A PARTICULAR SERVICE NOR THE PERFORMANCE OF ANY SYSTEM CONTAINING COMPONENTS MADE OR SOLD BY MAZZEI. |  | THE INFORMATION CONTAINED IN THIS DRAWING IS THE SOLE PROPERTY OF MAZZEI INJECTOR COMPANY LLC. ANY REPRODUCTION IN PART OR AS A WHOLE WITHOUT THE WRITTEN PERMISSION OF MAZZEI IS STRICTLY PROHIBITED. |  | <b>THIRD ANGLE PROJECTION</b><br>  |  | DRAWN:<br>T. JOHNS       |  | 11/28/2012      |  |  |  | <b>DEGAS SEPARATOR; DS 300</b> |  |                      |  |
| DRAWING MAY NOT BE PRINTED FULL SIZE<br>DO NOT SCALE  |  |  |  |   |  | CHECKED:<br>P. BANKOWSKI |  | 11/28/2012      |  | APPROVED:<br>P. BANKOWSKI  |  |                                |  | 11/28/2012           |  |
|   |  |  |  | QA:<br>-  |  | CUSTOMER APPROVAL:<br>-  |  | CUSTOMER:<br>NA |  | SIZE: <b>B</b>   |  |                                |  | JOB NO.: <b>NA</b>   |  |
|   |  |  |  |   |  |                          |  |                 |  | SCALE: <b>NONE</b>   |  | WEIGHT: <b>56 LBS</b>          |  | SHEET: <b>1 OF 2</b> |  |

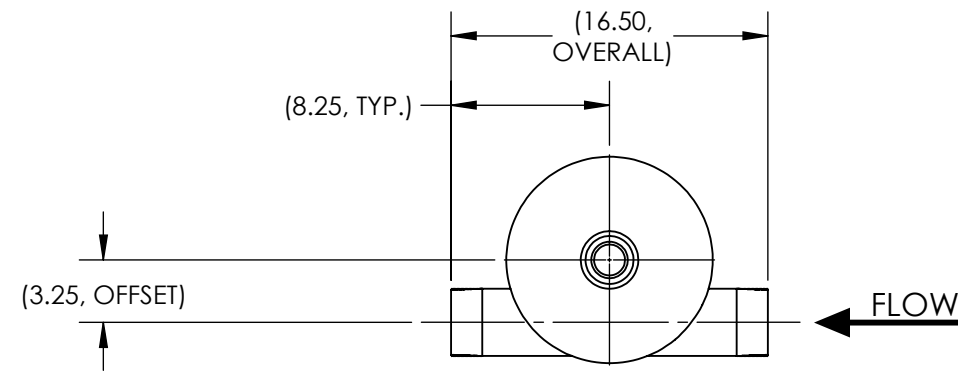

(TOP VIEW)

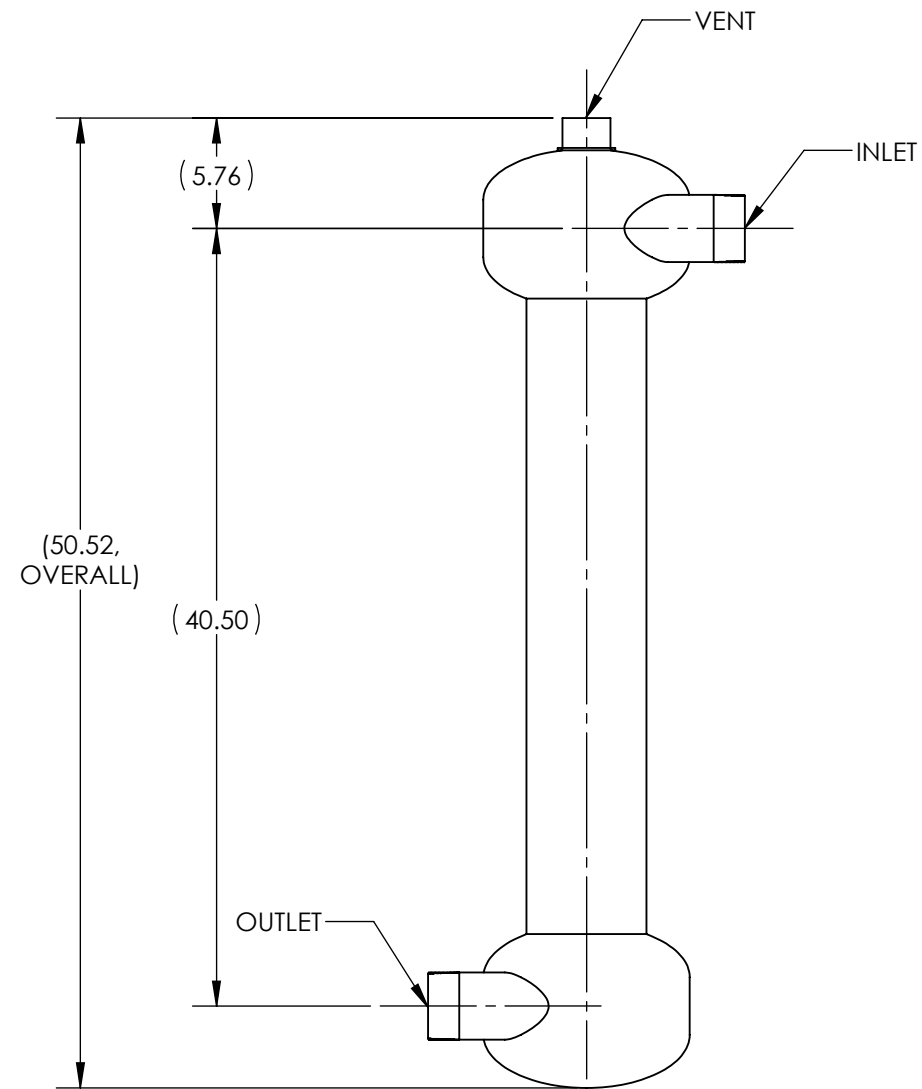

(SIDE VIEW)

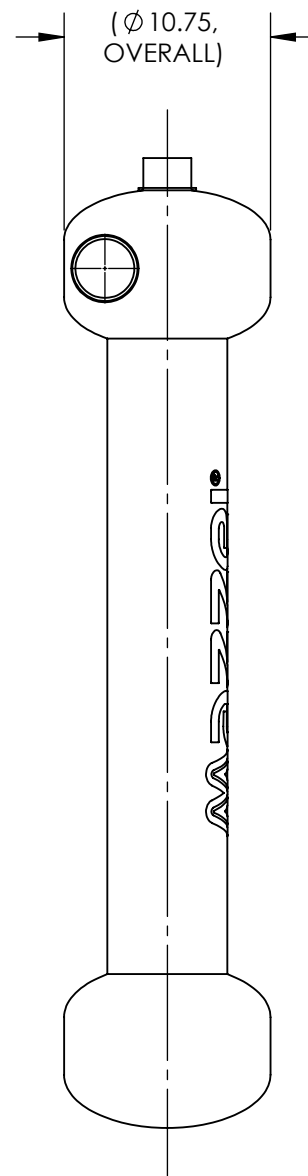

(END VIEW)

|   |          |  |          |
|---|----------|--|----------|
|  |          | <b>MAZZEI INJECTOR CO., LLC</b><br>500 ROOSTER DRIVE BAKERSFIELD, CA 93307<br>PHONE: (661) 363-6500 FAX: (661)363-7500<br>WWW.MAZZEI.NET |          |
|   |          | TITLE:<br><b>DEGAS SEPARATOR; DS 300</b>   |          |
| SIZE:   | JOB NO.: | DRAWING NUMBER:  | REV:     |
| <b>B</b>  | NA       | DSF03015ACF000-SUB   | <b>B</b> |
| SCALE:  | WEIGHT:  | SHEET:   |          |
| 1:10  | 56 LBS   | 2 OF 2   |          |

NOTES:

1. MATERIAL OF CONSTRUCTION: TYPE 316L, STAINLESS STEEL
2. MTR/HEAT NUMBERS ARE PROVIDED FOR ALL MATERIALS AND SHALL MEET APPLICABLE MATERIAL SPECIFICATIONS.
3. FLANGE BOLT HOLES TO STRADDLE COMMON CENTERLINES, UNLESS OTHERWISE NOTED.
4. MAXIMUM PRESSURE: 150 PSI (10.34 BAR)
5. MAXIMUM OPERATING TEMPERATURE: 180°F (82.2°C)
6. PRESSURE LOSS: 1 - 4 PSID (.07 - .28 BAR) AT RATED FLOW
7. RATED FLOW: 100 - 300 GPM (23 - 68 M³/HR)
8. EMPTY WEIGHT (DRY): APPROXIMATELY 91 LBS. (42 KG)
9. WATER VOLUME: 10 GALLONS (36.7 LITERS)
10. INLET/OUTLET CONNECTION:  
3.00" DIA., ANSI B16.5, CLASS 150, SCHED. 40, RAISED FACE, WELD NECK FLANGE
11. VENT CONNECTION:  
1.50" DIA., ANSI B1.20.1, FEMALE NATIONAL PIPE THREAD (FNPT)
12. FINISH: GLASS BLAST EXTERIOR ONLY
13. WELDING JOINTS TO BE COMPLETE PENETRATION, WHERE POSSIBLE.
14. DYE PENETRATE TESTING IN ACCORDANCE WITH ASME B31.3 NORMAL SERVICE RECOMMENDATIONS WILL BE PERFORMED ON A MINIMUM OF 20% OF LINEAR LENGTH OF WELDS; OR HYDROSTATIC TESTING WILL BE PERFORMED AS PART OF MAZZEI'S NON-DESTRUCTIVE TESTING PROCEDURE.
15. CLEANED FOR PASSIVATION PER ASTM A380 GUIDELINES.
16. PASSIVATED PER ASTM A967 SPECIFICATION.
17. WELD MAP, NON DESTRUCTIVE TESTING (NDT), CLEANING AND INSPECTION REPORTS TO BE PROVIDED BY MAZZEI.
18. MAZZEI RECOMMENDS INSTALLING THE DEGAS SEPARATOR PER THE O&M MANUAL GUIDELINES.

| REVISIONS |                         |           |            |
|-----------|-------------------------|-----------|------------|
| REV.      | DESCRIPTION             | DATE      | APPROVED   |
| NC        | RELEASED FOR SUBMITTAL. | 1/8/2014  | J. BENNETT |
| A         | REVISED NOTE 4          | 9/10/2015 | J. BENNETT |

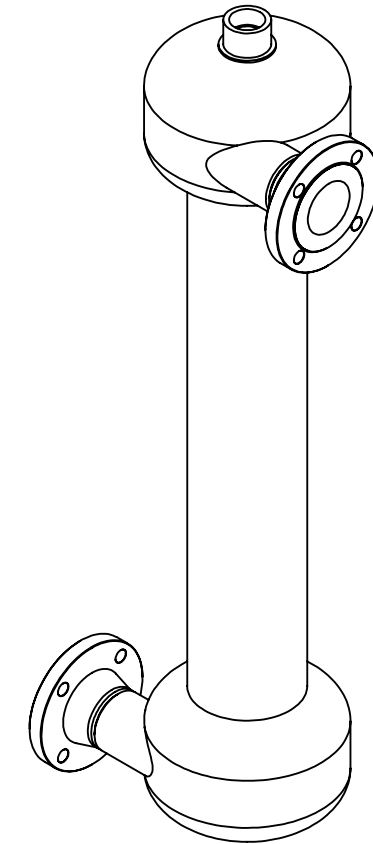

(ISOMETRIC VIEW)  
(FOR REFERENCE ONLY)

**SUBMITTAL DRAWING**

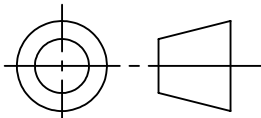
| SUBMITTAL NOTICE   |  | CONFIDENTIALITY NOTICE   |  | UNLESS OTHERWISE SPECIFIED<br>DIM ARE IN INCHES<br>TOL ON ANGLE ± .1/2°<br>1 PL ± .125 2 PL ± .060 3 PL ± .030<br>INTERPRET DIM AND TOL PER<br>ASME Y14.5M-1994 |  | APPROVALS               |  | DATE                 |  |  <b>MAZZEI INJECTOR CO., LLC</b><br>500 ROOSTER DRIVE BAKERSFIELD, CA 93307<br>PHONE: (661) 363-6500 FAX: (661)363-7500<br>WWW.MAZZEI.NET |  |
|--|--|--|--|---|--|-------------------------|--|----------------------|--|--|--|
| ANY RECOMMENDATIONS FOR PRODUCT AND/OR SYSTEM DESIGN, WHETHER CONTAINED IN A DOCUMENT, WITHIN THIS DRAWING, COMMUNICATED BY ELECTRONIC MEANS OR GIVEN VERBALLY, ARE INTENDED SOLELY AS GUIDELINES TO ACTUAL SYSTEM DESIGN. SAID RECOMMENDATIONS ARE BASED UPON INFORMATION SUPPLIED BY OTHERS, THE ACCURACY OF WHICH IS BEYOND VERIFICATION BY MAZZEI INJECTOR CO. LLC. THEREFOR MAZZEI CANNOT AND DOES NOT WARRANT THE SUITABILITY OF ITS PRODUCTS FOR A PARTICULAR SERVICE NOR THE PERFORMANCE OF ANY SYSTEM CONTAINING COMPONENTS MADE OR SOLD BY MAZZEI. |  | THE INFORMATION CONTAINED IN THIS DRAWING IS THE SOLE PROPERTY OF MAZZEI INJECTOR COMPANY LLC. ANY REPRODUCTION IN PART OR AS A WHOLE WITHOUT THE WRITTEN PERMISSION OF MAZZEI IS STRICTLY PROHIBITED. |  | <b>THIRD ANGLE PROJECTION</b><br>  |  | DRAWN:<br>T. JOHNS      |  | 1/8/2014             |  | <b>DEGAS SEPARATOR; DS 300</b>   |  |
|  |  |  |  |   |  | CHECKED:<br>K. COBAR    |  | 1/8/2014             |  |  |  |
| APPROVED:<br>J. BENNETT  |  | 1/8/2014   |  | QA:<br>-  |  | CUSTOMER APPROVAL:<br>- |  | SIZE: <b>B</b>       |  |  |  |
| DRAWING NUMBER:<br><b>DSF03015AAF000-SUB</b>   |  | REV: <b>A</b>  |  | SCALE: <b>NONE</b>  |  | WEIGHT: <b>91 LBS</b>   |  | SHEET: <b>1 OF 2</b> |  |  |  |

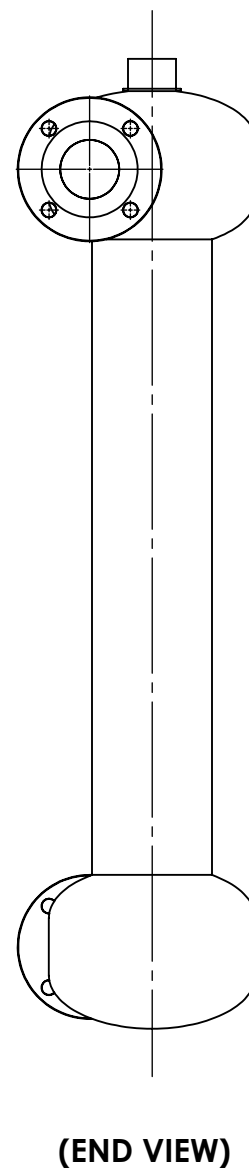
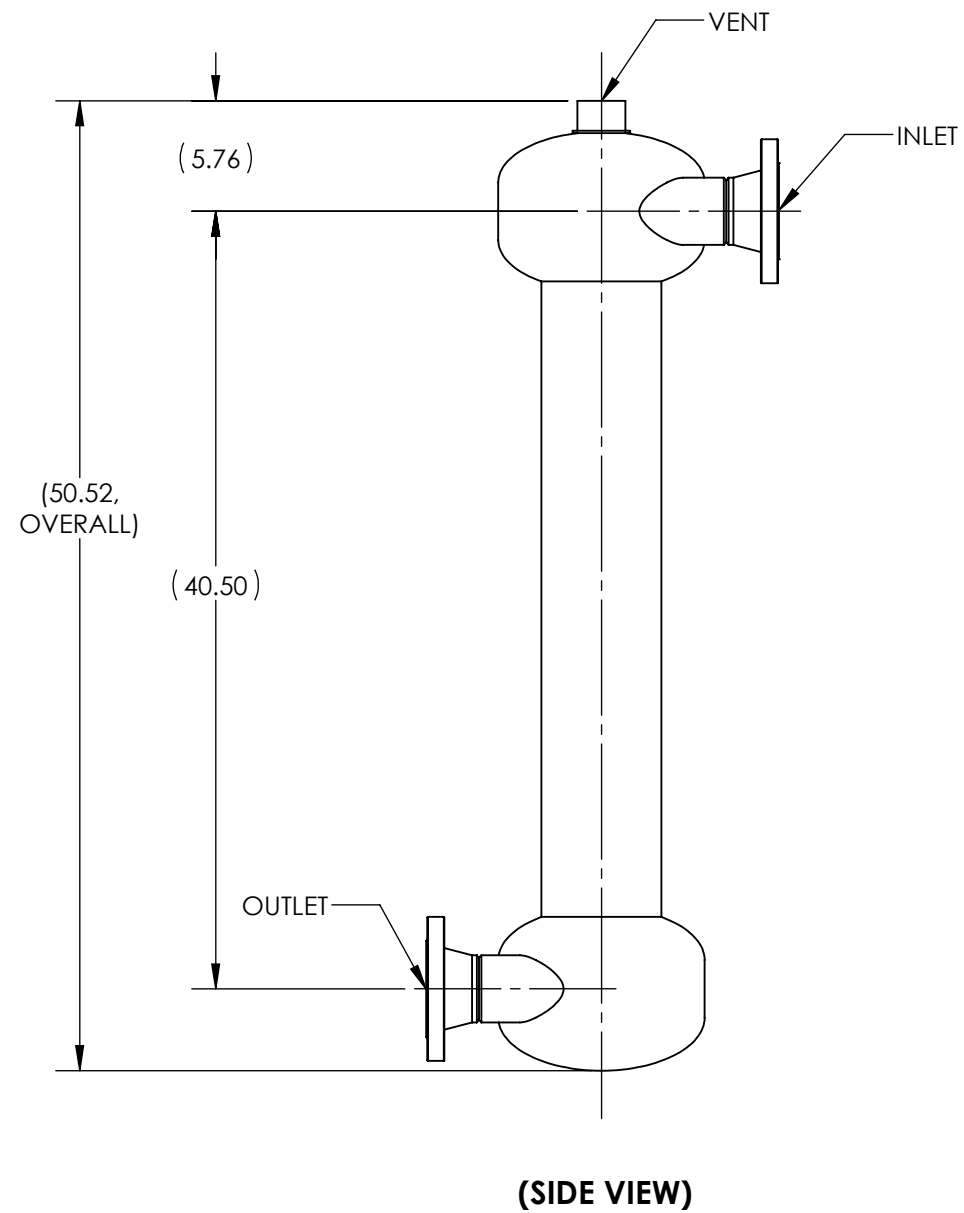
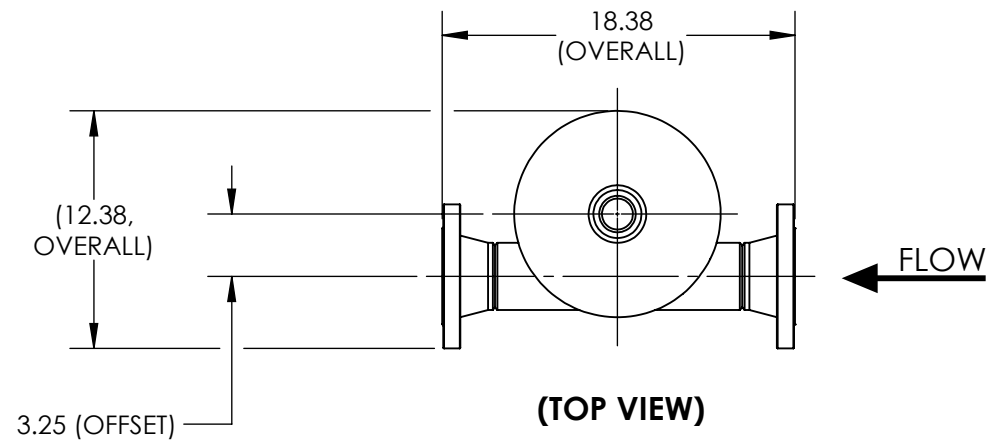

|   |          |  |          |
|---|----------|--|----------|
|  |          | <b>MAZZEI INJECTOR CO., LLC</b><br>500 ROOSTER DRIVE BAKERSFIELD, CA 93307<br>PHONE: (661) 363-6500 FAX: (661)363-7500<br>WWW.MAZZEI.NET |          |
|   |          | TITLE:<br><b>DEGAS SEPARATOR; DS 300</b>   |          |
| SIZE:   | JOB NO.: | DRAWING NUMBER:  | REV:     |
| <b>B</b>  | NA       | DSF03015AAF000-SUB   | <b>A</b> |
| SCALE:  | WEIGHT:  | SHEET:   |          |
| 1:10  | 91 LBS   |  | 2 OF 2   |

NOTES:

1. MATERIAL OF CONSTRUCTION: CHLORINATED POLYVINYL CHLORIDE (CPVC)/FIBER REINFORCED POLYMER (FRP)
2. MAXIMUM PRESSURE: 80 PSI (5.52 BAR)
3. MAXIMUM OPERATING TEMPERATURE: 73°F (22.8°C) @ MAX. PRESSURE
4. PRESSURE LOSS: 3 - 12 PSID (.2 - .8 BAR) AT RATED FLOW
5. RATED FLOW: 100 - 300 GPM (23 - 68 M<sup>3</sup>/HR)
6. EMPTY WEIGHT (DRY): APPROXIMATELY 77 LBS. (35 KG)
7. WATER VOLUME: 15.2 GALLONS (57.4 LITERS)
8. INLET/OUTLET CONNECTION:  
3" NOMINAL DIA., CLASS 150, VAN STONE STYLE FLANGE
9. VENT CONNECTION:  
2" NOMINAL DIA., CLASS 150, VAN STONE STYLE FLANGE
10. FINISH: FIBERGLASS WRAPPED EXTERIOR ONLY
11. HIGH FREQUENCY SPARK TEST REPORT OF HOT AIR WELDS CAN BE PROVIDED BY MAZZEI UPON REQUEST.

| REVISIONS |                         |           |            |
|-----------|-------------------------|-----------|------------|
| REV.      | DESCRIPTION             | DATE      | APPROVED   |
| NC        | RELEASED FOR SUBMITTAL. | 2/19/2015 | J. BENNETT |

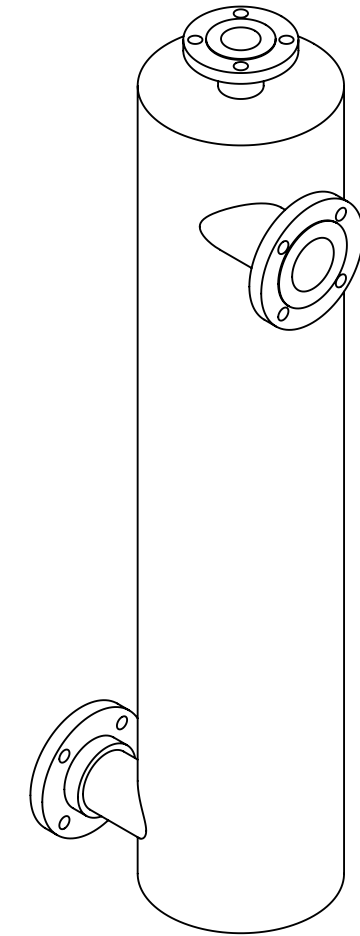

(ISOMETRIC VIEW)  
(FOR REFERENCE ONLY)

**SUBMITTAL DRAWING**

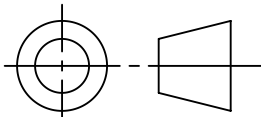
|   |  |  |  |  |  |                         |  |                  |  |  |  |  |  |
|---|--|--|--|--|--|-------------------------|--|------------------|--|--|--|--|--|
| <b>SUBMITTAL NOTICE</b>   |  | <b>CONFIDENTIALITY NOTICE</b>  |  | UNLESS OTHERWISE SPECIFIED<br>DIM ARE IN INCHES<br>TOL ON ANGLE ± .50°<br>ALL DIMS ± 1"<br>INTERPRET DIM AND TOL PER<br>ASME Y14.5M-1994 |  | APPROVALS               |  | DATE             |  |  <b>MAZZEI INJECTOR CO., LLC</b><br>500 ROOSTER DRIVE BAKERSFIELD, CA 93307<br>PHONE: (661) 363-6500 FAX: (661)363-7500<br>WWW.MAZZEI.NET |  |  |  |
| ANY RECOMMENDATIONS FOR PRODUCT AND/OR SYSTEM DESIGN, WHETHER CONTAINED IN A DOCUMENT, WITHIN THIS DRAWING, COMMUNICATED BY ELECTRONIC MEANS OR GIVEN VERBALLY, ARE INTENDED SOLELY AS GUIDELINES TO ACTUAL SYSTEM DESIGN. SAID RECOMMENDATIONS ARE BASED UPON INFORMATION SUPPLIED BY OTHERS, THE ACCURACY OF WHICH IS BEYOND VERIFICATION BY MAZZEI INJECTOR CO. LLC. THEREFORE MAZZEI CANNOT AND DOES NOT WARRANT THE SUITABILITY OF ITS PRODUCTS FOR A PARTICULAR SERVICE NOR THE PERFORMANCE OF ANY SYSTEM CONTAINING COMPONENTS MADE OR SOLD BY MAZZEI. |  | THE INFORMATION CONTAINED IN THIS DRAWING IS THE SOLE PROPERTY OF MAZZEI INJECTOR COMPANY LLC. ANY REPRODUCTION IN PART OR AS A WHOLE WITHOUT THE WRITTEN PERMISSION OF MAZZEI IS STRICTLY PROHIBITED. |  | <b>THIRD ANGLE PROJECTION</b><br>                   |  | DRAWN:<br>T. JOHNS      |  | 2/19/2015        |  |  |  | DESCRIPTION:<br><b>DEGAS SEPARATOR; DSF03020KAAFID</b> |  |
| DRAWING MAY NOT BE PRINTED<br>FULL SIZE DO NOT SCALE  |  |  |  |  |  | CHECKED:<br>J. PEREZ    |  | 2/19/2015        |  | APPROVED:<br>J. BENNETT  |  |  |  |
|   |  |  |  | QA:<br>-   |  | CUSTOMER APPROVAL:<br>- |  | CUSTOMER:<br>N/A |  | SIZE:<br><b>B</b>  |  | JOB NO.:<br>N/A  |  |
|   |  |  |  | DRAWING NUMBER:<br>DSF03020KAAFID-SUB  |  | REV:<br>NC              |  | SCALE:<br>NONE   |  | WEIGHT:<br>77 LBS  |  | SHEET:<br>1 OF 2                                       |  |

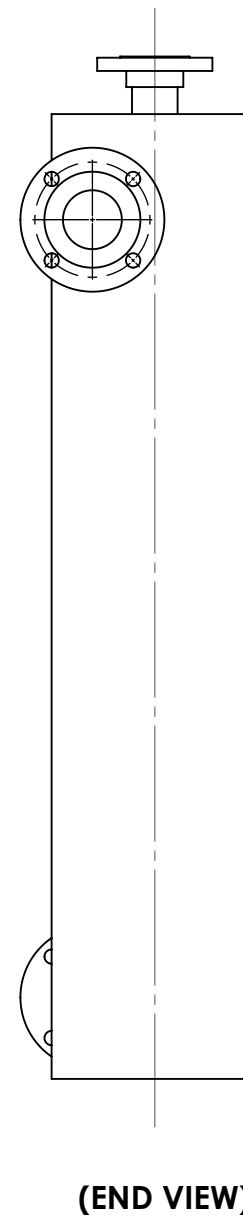
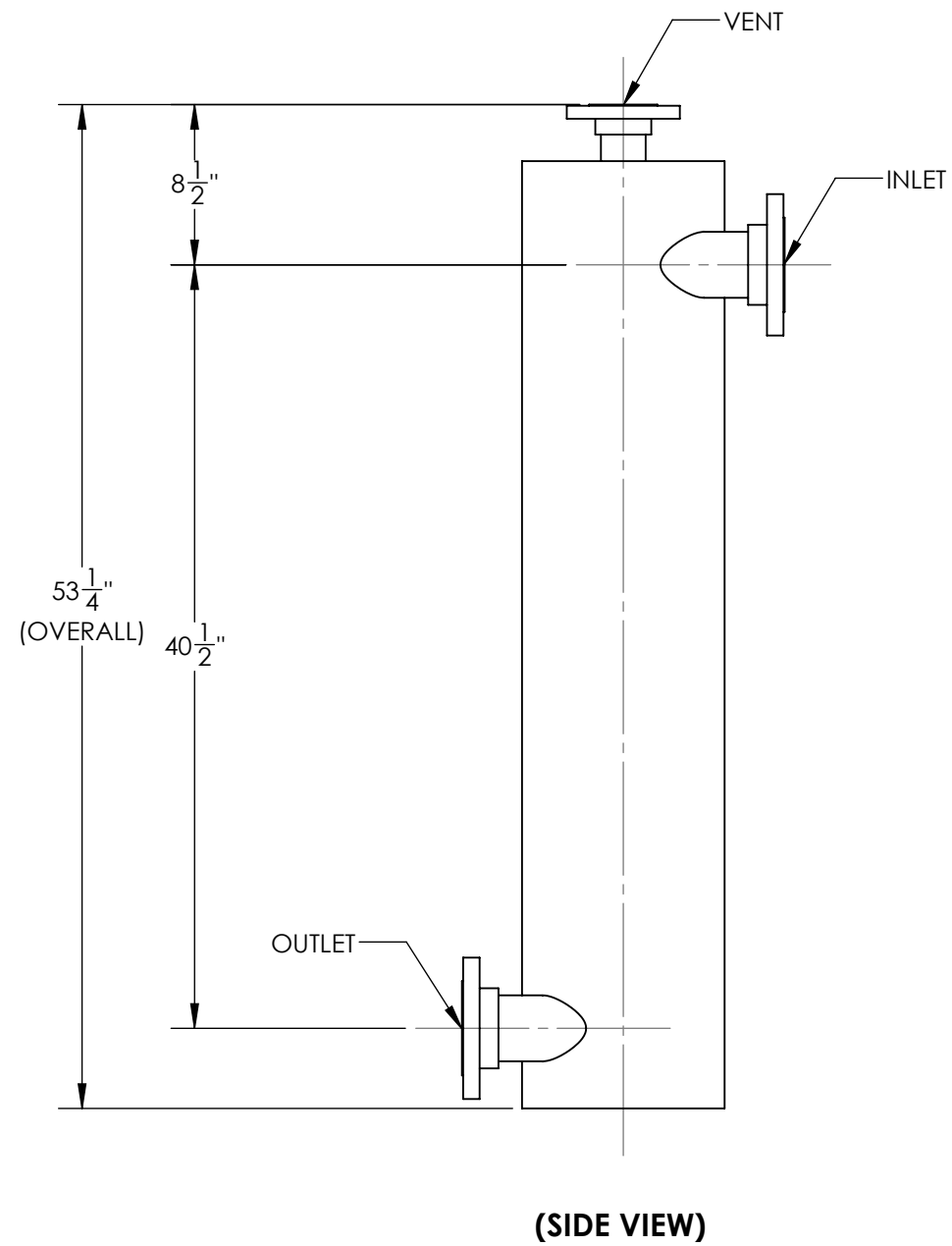
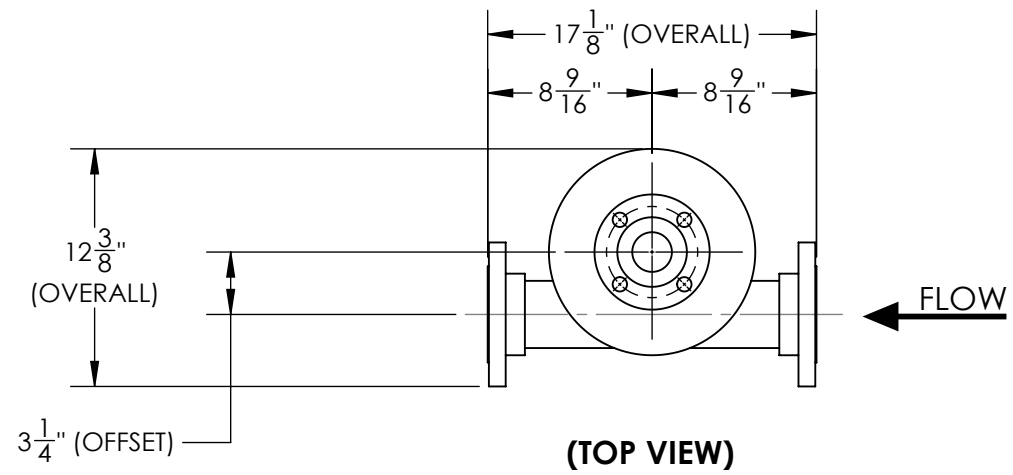

|   |          |  |      |
|---|----------|--|------|
|  |          | <b>MAZZEI INJECTOR CO., LLC</b><br>500 ROOSTER DRIVE BAKERSFIELD, CA 93307<br>PHONE: (661) 363-6500 FAX: (661)363-7500<br>WWW.MAZZEI.NET |      |
|   |          | DESCRIPTION:<br><b>DEGAS SEPARATOR; DSF03020KAAFID</b>   |      |
| SIZE:   | JOB NO.: | DRAWING NUMBER:  | REV: |
| <b>B</b>  | N/A      | DSF03020KAAFID-SUB   | NC   |
| SCALE:  | WEIGHT:  | SHEET:   |      |
| 1:10  | 77 LBS   | 2 OF 2   |      |